

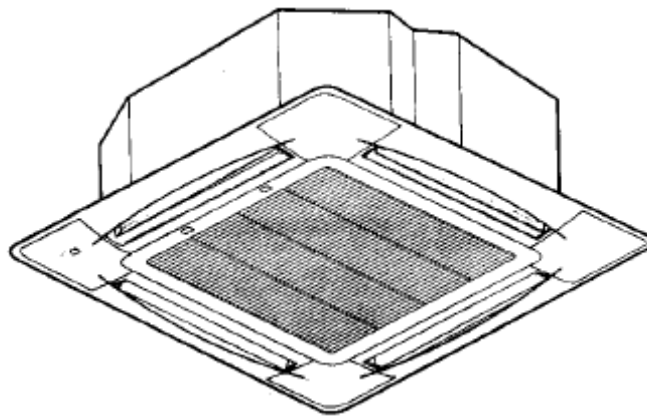

Highcool 2007 Series

Installation & Operation Manual

Built In Cassette Heat Pump Systems



- Installation should only be carried out by fully trained & qualified technicians.
- For your convenience, please read this manual thoroughly and follow its instructions carefully
- Please keep this manual in good condition for your reference.

Cassette Heat Pumps R410a

Introduction

Thank you for choosing this AUX Highcool series cassette air conditioner. This unit is designed to provide many years of energy efficient and reliable operation if installed and operated correctly, according to the instructions in this manual.

Highcool series cassette air conditioners are designed for installation by Trained and Qualified personnel and are not suitable for DIY projects. In particular High Voltage Electrics and High Pressure Refrigerant Gas, as well as moving parts, present many potential hazards to health.

This manual is designed to provide a suitably qualified and trained Installation Professional with the specialist information required to install and operate the unit in the manner for which it was designed.

Applicable Models

Highcool series cassette systems are supplied in three separate boxes for assembly on site. These contain the indoor unit supplied complete with a remote wired controller, outdoor unit and grille.

This manual refers to the following models, which are designed to work together, and should not be used for any other model or combination.

Class	Indoor Unit	Outdoor Unit	Grille
5KW	SC187	OC187	SG187
7KW	SC247	OC247	SG247
12KW	SC427	OC427	SG427

If you have any queries please contact Medal Aircon Accessories on 01743 466333

Table of Contents

Technical Data	4
Safety Precautions	5-7
Grille	7
System Components	8
Wired Controller	8-13
Service & Maintenance	14-17
Indoor & Outdoor Installation	18-25
Pipe work Connections	25-30
Electrical Connections	31-32
Installing the Controller	33
Commissioning	33
Appendixes	34-42
Commissioning Sheet	43

Model References

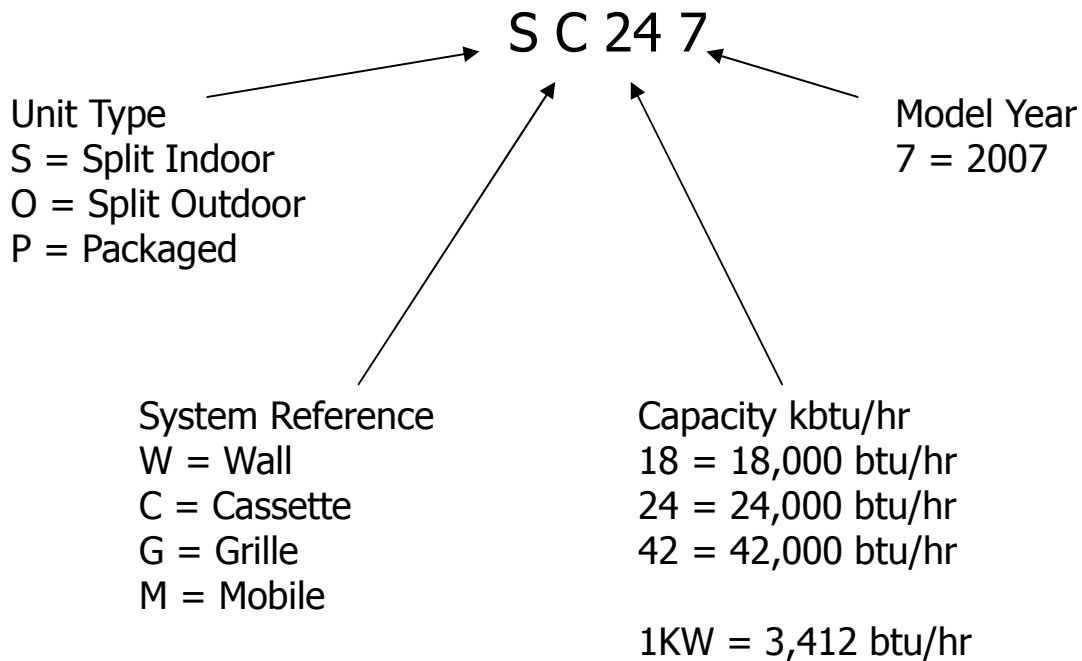

Warning

This Manual is designed for experienced and qualified Installation and Service Engineers and not for the General Public. It does not contain specific warning or cautionary information for non technical individuals. Attempts to install or service this system by unqualified personnel carries the risk of serious injury or death.

This air conditioner is not intended for use by persons (including children) with reduced physical, sensory or mental capabilities, or lack of experience and knowledge, unless they have been given supervision or instruction concerning use of the appliance by a person responsible for their safety. Children should be supervised to ensure they do not play with the air conditioner or remote controller.





Technical Data

Indoor Unit	SC187	SC247	SC427
Outdoor Unit	OC187	OC247	OC427
Panel	SG187	SG247	SG427
Total Cooling KW	5.0	7.0	12.0
Heating KW	5.5	7.7	13.5
Cooling Input KW	1.8	2.6	4.6
Heating Input KW	1.8	2.3	4.7
Cooling Input Amps	8.4	12.1	8.2
Heating Input Amps	8.4	10.3	8.4
EER Cooling	3.1	3.0	2.9
COP Heating	3.5	3.7	3.2
Energy Class Cooling	B	C	C
Energy Class Heating	B	A	D
Max Input Amps	11.0	18.1	11.0
Input Voltage	220-240V	220-240V	380-415V
Power Supply	1ph ~	1ph ~	3ph 3N~
Indoor Air Flow m ³ /hr	900	1300	1800
Indoor Noise dBA	42	45	50
Outdoor Noise dBA	52	56	60
Indoor H x W x D	255x570x570	240x835x835	280x835x835
Outdoor H x W x D	590x800x300	690x800x300	940x950x350
Panel H x W x D	30x650x650	55x950x950	55x950x950
Indoor Weight Kg	16	25	30
Outdoor Weight Kg	43	54	94
Panel Weight Kg	3	5	5
Liquid Pipe Size	1/4"	3/8"	3/8"
Gas Pipe Size	1/2"	5/8"	3/4"

1. AUX products are subject to continual improvement and data may change without notice.
2. If the data on the product nameplate differs from the above then the data on the nameplate shall be taken as correct.
3. Errors and Omissions Excepted
4. Cooling Performance is measured at 27/19 C db/wb air entering the indoor unit and 35C db outdoor temperature with High Fan Speed.
5. Heating Performance is based upon 20C db air entering the indoor unit and 7/6C db/wb outdoor temperature with High Fan Speed.

Safety Precautions





- Before starting the Air Conditioner, ensure you have read the Safety Precautions, in order to ensure correct operation of the system. Allow 8 hours after connection of electrical power before operating this air conditioner.
- After reading this manual please keep it in good condition for reference. If the air conditioner is ever sold or transferred to others then this manual should be transferred along with it.
- The following symbols are used in this manual for your protection

				
WARNING Danger of Serious Personal Injury or Death.	CAUTION Danger of Serious Accident	Please do as Instructed	Do Not	Install an Earth Connection

1—Installation Precautions













WARNING

	This system is designed for comfort cooling for offices, shops and light commercial premises. It is not designed for workshops or operation in arduous conditions.		Installation by qualified, trained and experienced service personnel only Not suitable for DIY installations
	This system contains refrigerant gas under pressure. Leakage of gas constitutes a potential health hazard due to frostbite or asphyxiation and violates COSHH legislation.		Electrical Installation by qualified Electrical Installation Engineers Only Follow the IET regulations





CAUTION

					
Install Earth Leakage Circuit Breaker maximum 30mA. Install Isolator within arms reach of indoor & Outdoor Unit	Install Drains Correctly to avoid water leakage. Do not drink the condensate water produced. Drains must be trapped.	Confirm the system is properly Earthed in accordance with National & Local Requirements. Danger of Injury or Death.			
			In the event of a gas leak ventilate the affected area. Do not expose gas to naked flame. Consider Leak Detection for small rooms.		Ensure units pipes and cables are securely fixed. Securely attach all covers. Check nothing is loose.
Read & Follow the Installation & Operation Instructions					

1—Operation Precautions













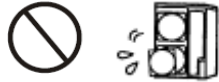

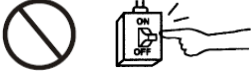

WARNING

 <p>Do not set the temperature too low or stay in the cold air stream for long periods. Discomfort or damage to health can result.</p>	 <p>Do not poke sticks or other items into the air grilles. The fans run at high speeds and this poses a danger of injury and damage.</p>	 <p>If you experience abnormal sounds and / or odours (for example a burning smell) stop the unit, isolate it electrically immediately and contact your installer. Continued operation risks breakdown, electric shock or fire.</p>
---	--	--



CAUTION

 <p>Do not operate with wet hands—risk of electric shock.</p>	 <p>Do not wash with water. Isolate electrically before cleaning. Danger of electric shock.</p>	 <p>Never operate the air conditioner with protective grilles removed.</p>	 <p>Do not place sprays on the air conditioner. Never spray into the air conditioner</p>
 <p>Do not use for storing items such as artworks or other special purposes</p>	 <p>Do not use gas fires where the airflow can interfere with combustion</p>	 <p>Do not sit on the air conditioner or place objects that may fall off on it</p>	 <p>Do not let the unit blow directly onto children, animals or plants</p>
 <p>Use a correctly sized fuse or circuit breaker. Using wire can start a fire.</p>	 <p>Do not use the power switch to start & stop the unit. Danger of Fire.</p>	 <p>Ensure the room is adequately ventilated.</p>	 <p>Do not operate electronic devices within 1 metre of your system</p>
 <p>Do not use kettles near units or controllers. Steam can cause malfunction or damage.</p>	 <p>Regularly check that unit supports are not damaged. Danger of Injury or Death.</p>	 <p>Do not place containers with liquids on top of the air conditioner. Water entry can cause damage or injury.</p>	 <p>After a long period without electrical power, do not operate for 8 hours when power is restored.</p>



WARNING

With the exception of the filter, which must be cleaned regularly, this air conditioner contains no user serviceable parts. Do not attempt to service or repair this system yourself. Regular Service & Preventative Maintenance by a qualified professional is essential for correct operation and failure to have this carried out may cause failure and invalidate the warranty.

3—Moving & Repair Precautions

CAUTION



Do not attempt to repair the air conditioner yourself.

All service work must be carried out by a qualified and trained professional.



Do not attempt to move, reinstall, or decommission the air conditioner yourself.

This work must be carried out by a qualified and trained professional.

Panel Components

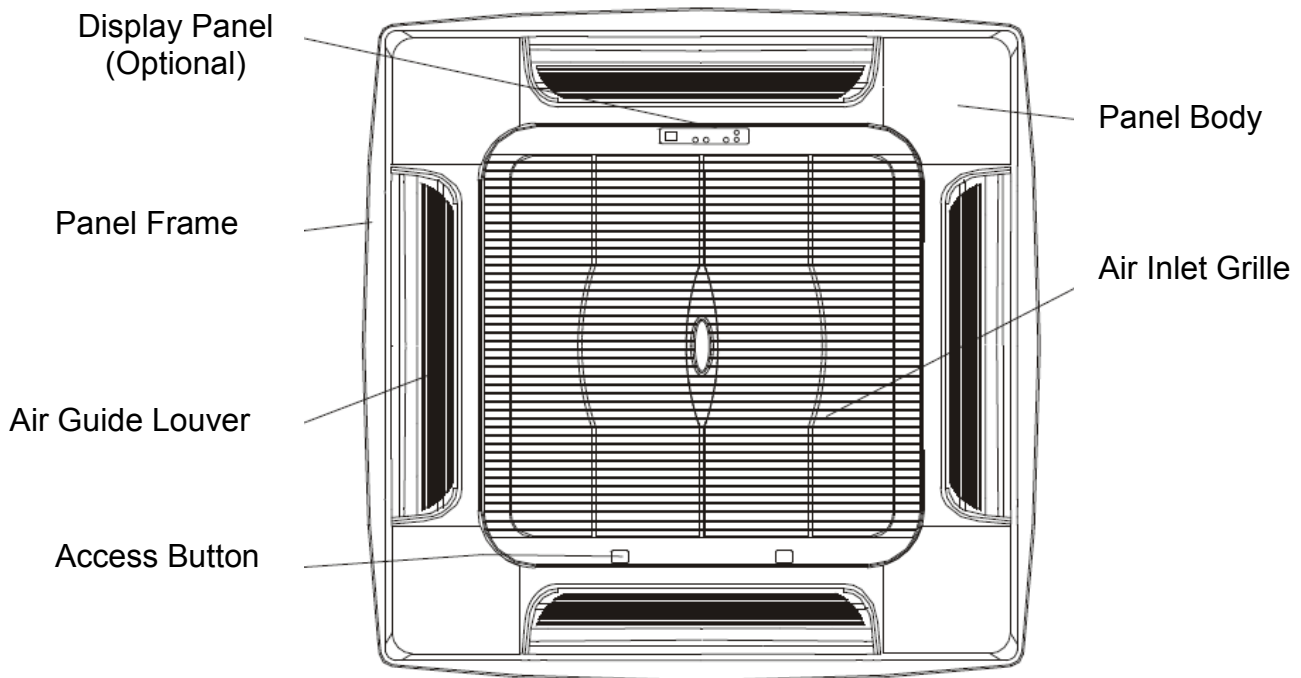

Access to the Filter for cleaning requires depression of the 2 Access Buttons and lowering of the air inlet grille. We recommend checking the state of the filter weekly.

CAUTION

For correct use of this air conditioner please ensure the following

- Ensure that the unit is used according to the instructions contained in this manual or malfunction may occur.
- Pay particular attention to the instructions for setting the air conditioner. Using an incorrect temperature setting can cause discomfort, health problems and also malfunction
- Electromagnetic Radiation can affect the operation of the unit and cause it to malfunction. If this occurs then the unit can be restarted by disconnecting the power supply for three minutes and then restarting
- It is important that the air inlet and outlet for both indoor and outdoor unit are kept free of obstructions.
- Do not operate the indoor unit in abnormally high humidity. Condensation can result.
- The Air Filter in the indoor unit grille must be cleaned regularly to prevent malfunction and ensure optimum performance.

Note—The system contains both liquid and gas refrigerant under pressure. Occasional sounds such as 'whoosh' or 'glug glug' are normal and an indication the system is operating correctly.

System Components

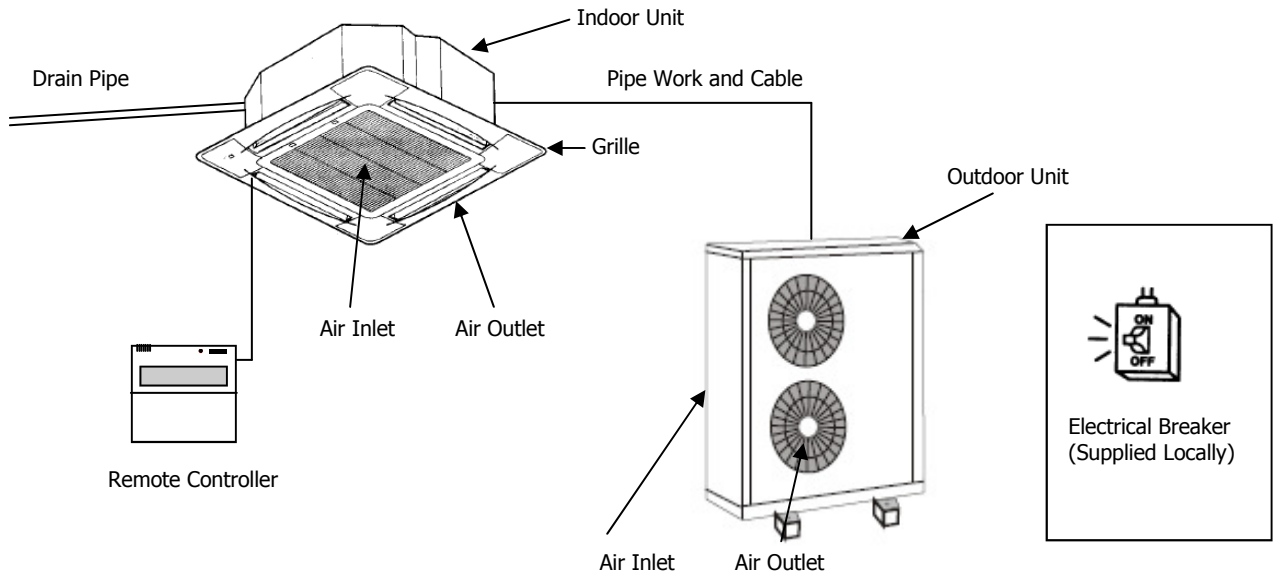

Operating the Air Conditioner

A wired remote controller is used to operate the unit and also display the status of the system and important system information. It can also display faults, be used to program system settings and also contains a time clock to operate the unit according to a time program.

General Description

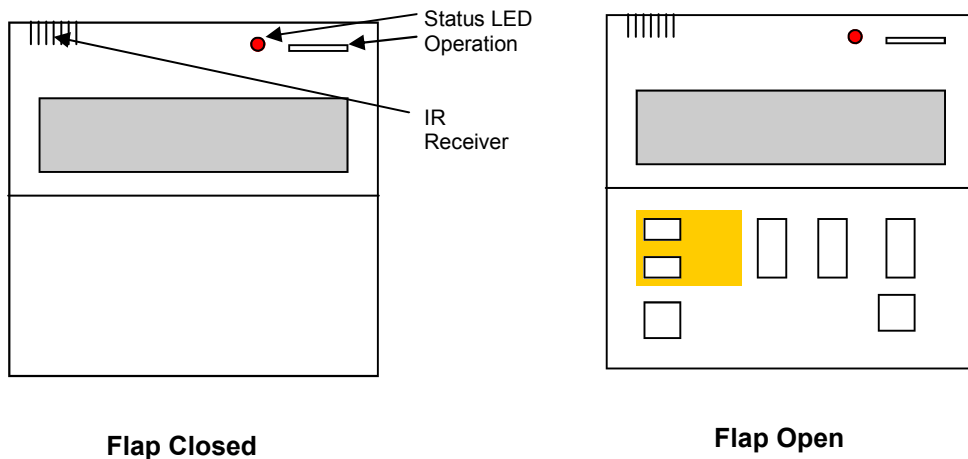

The controller has a Backlit Liquid Crystal Display Section, Status LED and Operation Switch mounted on the top half. The lower half is covered by a swing open flap.

Opening the flap reveals the control buttons. These are used to operate the unit. The buttons with a yellow border control the timer operation and the others control the units other functions.

Please Ensure -

- Do not operate the controller with wet hands
- Do not press multiple buttons simultaneously
- Do not press the buttons with sharp objects
- Ensure the Correct Button is Pressed
- Ensure all settings are in accordance with the Units User Manual
- Do not get the controller wet

Wired Controller

Display Section

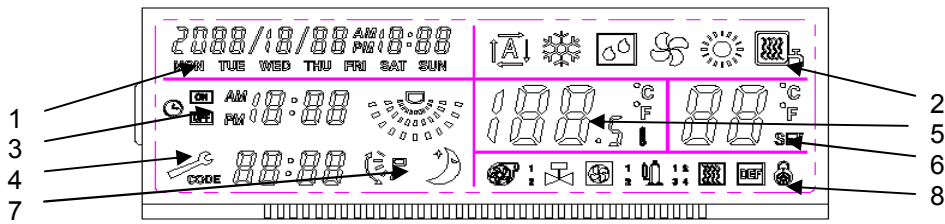

Display Segments

1. **Clock Area**—Displaying the date, time and day of the week
2. **Mode Display**—Showing your choice of Automatic, Cooling, Dry, Fan Only and Heating Modes
3. **Timer Area**—Displaying the next Timer Occurrence and whether the unit will turn On or Off at this time. If this is not displayed then the unit is not in Timer Mode
4. **Error Code Display Area**—This displays any applicable error conditions
5. **Temperature Display Area**—This displays the Temperature as measured by the unit
6. **Set Temperature Display Area**—This displays the temperature the unit is trying to achieve
7. **Fan and Louver Display Area**—This shows the current fan setting and whether the swing louver is operational.
8. **Output Device Display Area**—This shows which output devices are operational. These include water pump, reversing valve, outdoor fan motor, compressor, electric heater and defrost. It also displays whether the keyboard lock has been set.

Control Buttons

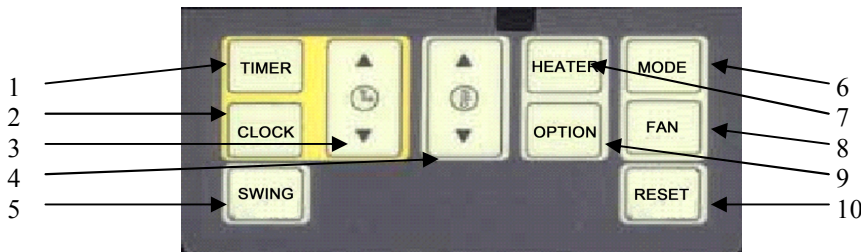

Operation Switch & Status LED

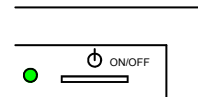

Press the operation switch to turn the unit on and off.

The status LED glows red for off and green for on.

Opening the panel on the front of the controller reveals the controller buttons which allow you to control the functions of the air conditioner. In brief this page describes their main functions.

1. **Timer**—Pressing this button turns the timer function on and off. Pressing and holding with the unit off allows the timer to be set.
2. **Clock**—Pressing and holding with the unit off allows the date, time and day of the week to be set.
3. **Time Up & Down**—These can be used to set the time in Clock Set or Timer Set modes.
4. **Temperature Up & Down**—These can be used to increase or decrease the set temperature.
5. **Swing**—This is used to enable or disable the swing louver
6. **Mode**—This is used to switch between operating modes. You can use this to select Automatic, Cooling Only, Heating Only, Dehumidification or Fan Only operation for your air conditioner.
7. **Heater**—This function is used to control an optional electric heater element if one is fitted. Your Highcool air conditioner does not include this device but uses the outdoor unit to generate heat in heating mode.
8. **Fan**—This is used to set the fan speed and pressing it will scroll between low, medium, high and automatic fan speeds.
9. **Option**—Pressing this allows the user to use the temperature up & down buttons to interrogate the various temperature sensors in the indoor and outdoor units.
10. **Reset**—This can be used when you are in any programming mode to return to standard operational mode. Pressing and holding this button allows the keyboard lock to be set.

Understanding the Display

2000/10/00 AM 10:00
 2000/10/00 PM 10:00
 MON TUE WED THU FRI SAT SUN

The Clock Area shows the Date, Time and Day of the week.

Pressing and holding the CLOCK button with the unit off allows these parameters to be scrolled through and changed using the TIME UP & DOWN buttons to increase and decrease the setting and the CLOCK button to scroll to the next function. After setting the date, time and day of the week press RESET to leave the programming mode.



The Mode Area shows which mode the unit is currently set to work in. This is set using the MODE button on the controller.



Automatic mode allows the unit to automatically select heating or cooling in order to maintain the desired room temperature. For your comfort we recommend setting the temperature to between 22 & 24C in automatic mode.



Cooling Mode allows cooling to be used to prevent the room temperature exceeding the set temperature during summer-time use. For your comfort we recommend not setting the desired temperature below 22C in cooling mode.



Dry or Dehumidification Mode uses the units cooling function to reduce the humidity in the room. It is designed to make the room comfortable with reduced energy consumption compared with cooling mode.



Fan Only Mode uses the indoor fan to generate air movement within the room but without cooling or heating the room. It is often used to prevent a room getting 'stuffy'



Heating Mode allows heating to be used to prevent the room temperature dropping below the set temperature during winter use. For your comfort we recommend not setting the temperature above 24C in heating mode.



The Timer Area is only lit during timer operation and shows the time when the timer will next turn the unit on or off. If the unit is in timer operation and the OPERATION button is pressed then the timer area will advance to the next applicable setting as the OPERATION button over rides the current setting.

Setting the timer can only be carried out when the unit is off. Press and hold the TIMER button. You can then set a start and stop time for every day of the week using the TIME UP & DOWN buttons to increase or decrease the time and the TIMER button to scroll between the settings. For every day of the week you can select the unit to either run or not. Use the TEMPERATURE UP & DOWN buttons to scroll between ON and OFF for that day of the week. Press RESET to leave programming mode.

If you wish to operate the unit manually without time clock operation press the TIMER button until there is no display in the Timer Area. To resume press the TIMER button to show the Timer Area.



The Error Code Display Area is lit when there is a fault which must be rectified. Depending upon the nature of the fault the unit may continue to operate or shut down.

On seeing an Error Code you should immediately inform your service engineer and give them the fault code. An explanation of these fault codes are shown in the appendix of this manual.



The Temperature Display Area shows the temperature of the room as measured at the units Air Inlet.

Pressing the OPTION button allows the temperatures of the other temperature sensors to be displayed here using the TEMPERATURE UP & DOWN buttons to scroll through them. The sensor reference is shown in the Error Code Display Area. Press RESET to leave this mode.



The Set Temperature Display Area shows the temperature the unit is set to achieve when operating. This temperature can be increased or decreased using the TEMPERATURE UP & DOWN buttons.

In order to achieve the best results we recommend that a setting of between 22C and 24C will give the best results in terms of room comfort. Constant changes in set temperature will not give better comfort but will increase energy consumption. Operating the unit with an abnormally low set temperature in cooling or abnormally high set temperature in heating for extended periods may also cause erroneous operation.

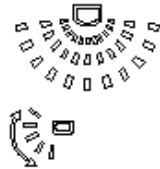

The Fan & Louver Display Area shows the fan speed and also whether the automatic swing louver is operational.

To start or stop the swing louver mechanism press the SWING button. All four louvers operate simultaneously and can not be controlled individually. This function can only be set when the unit is running.

To change the fan speed press the FAN button when the unit is running. This will scroll between high, medium, low and automatic fan speeds.









Swing Louver Low Fan Speed Medium Fan Speed High Fan Speed

Automatic Fan Speed is shown by the display continually changing from low to medium to high fan speed.

In order to prevent malfunction it is recommended not to use the low or medium fan speed settings when using the unit in cooling or automatic modes with a set temperature below 21C or in heating or automatic modes above 25C. Under certain conditions the units internal controls may over ride the fan speed selected by the user.



The Output Device Display Area is designed to show which of your systems internal components are operating at that moment in time, except for the Indoor Fan and Swing Louver which are shown separately in the Fan & Louver Display Area. It can also display if the keyboard lock is set.

-  The Internal Drain Pump is used to remove condensate water produced during cooling, automatic and dry modes from the indoor unit.
-  The Reversing Valve is used to reverse the flow of refrigerant in order to allow the unit to heat instead of cool. This is lit in heating mode.
-  The Outdoor Fan is used to reject heat from the room in cooling or dry modes or collect heat from outside in heating mode.
-  The compressor is used to pump refrigerant around the system to allow the unit to heat or cool. It is located in the outdoor unit.
-  The electric heat symbol is used to show when an optional electric heater device is energised. Your Highcool unit does not have this heater and if it is displayed you can cancel it using the HEATER button. It has no effect on your unit.
-  The Defrost Symbol shows when the unit is in heating but has stopped to melt any ice formed on the outdoor heat exchanger. This will happen from time to time to allow the system to operate efficiently.
-  The Keyboard Lock is used to prevent unauthorised access to the controller. When it is lit none of the keys on the controller can be used. This allows the operator to set the units operating mode and start / stop times then prevent others from interfering with the operation of the system. It is enabled or disabled by pressing and holding the RESET button for six seconds.

Getting Started

Setting the Time, Date & Day of the Week

1. Press and hold CLOCK until a beep is heard
2. One of the segments of the Time Display will flash
3. Use TIME UP & DOWN to set that segment
4. Use CLOCK to scroll to the next segment
5. Use RESET to finish when the time, date and day of the week have been set.

Setting the Time Clock

Each day has a start time, stop time and whether the time clock is active for that day of the week. The time clock is only activated if a start or stop time is shown in the Timer Display segment of the LCD Display. This must be done with the unit off.

1. Press and hold TIMER until a beep is heard
2. The Timer Display will be shown as well as a day of the week and a large ON or OFF. One of the segments will flash.
3. Use TEMPERATURE UP & DOWN to set whether the unit will run that day or not.
4. Use TIME UP & DOWN to change the flashing segment to the desired setting.
5. Use TIMER to scroll to the next segment
6. When the day of the week changes go back to step 3
7. When each day has a start and stop time and has been set to on or off press RESET

Typical settings are 8.00am start and 5.00pm stop with Monday to Friday set to ON and Saturday and Sunday set to OFF.

Enabling or Disabling the Time Clock

If a start or stop time is shown in the Timer Display section the time clock is active. If it is not then it is inactive. Press TIMER to enable or disable the time clock.

Operating the System Manually

1. Ensure the time clock is disabled by pressing TIMER if there is a start or stop time displayed in the Timer Display LCD section.
2. Press OPERATION (ON/OFF in the top right hand corner of the controller) to switch the unit on or off.
3. If the unit is on then the display LED will glow green. If it is off then it will glow red.

What do you want the unit to do?

Pressing the mode button scrolls between automatic, cooling, dry, fan only and heating modes. Choose the mode most appropriate to your needs.

- Automatic will engage whichever mode is necessary to maintain the set temperature
- Cooling will cool the room down to the set temperature
- Dry will remove moisture and cool the room down.
- Fan Only will give air movement in the room without heating and cooling
- Heating will heat the room up to the set temperature

Note—the unit will only be able to reach the set temperature if it is powerful enough to do so. Your air conditioner is not designed to cool a room down to 20C or less for long periods or heat it up to 25C or more for long periods. Depending upon the heating or cooling requirements of your room the unit may be unable to do so at all.

Setting the Set Temperature

Use TEMPERATURE UP & DOWN to increase or decrease the set temperature to the required level. We recommend between 22C & 24C for an optimum comfort level.

Setting the Auto Swing Louver

Press SWING while the unit is operating to start or stop this function.

Setting the Indoor Fan Speed

Press FAN while the unit is running to increase or decrease the indoor fan speed or choose automatic fan speed to let the unit choose the most appropriate.

Setting the Keyboard Lock

Press and hold RESET for six seconds to turn the keyboard lock on and off.

Advanced Settings

Remote Start & Stop

YES/NO

It is possible to provide the unit with a remote over ride switch to turn the unit on or off remotely using a central time clock or switch. Check with your installer whether this has been done and for future reference make a note above if this is the case.

It is still possible to operate the unit using the time clock on the unit while this function is operating but the remote switch will always take priority over any local setting.

Temporary Start / Stop

If the unit is operating in time clock mode then pressing the OPERATION button will temporarily advance the operation. The unit will stop if it is running or start if it is off. The Timer Display will change to the next on or off period and at this time will resume time clock operation.

Temporary Timer

Pressing TIMER when not in time clock mode will allow a temporary on or off time to be set. This is set in a similar manner to setting the time clock and once the time is set pressing RESET will allow the unit to function under this temporary setting. Alternatively pressing TIMER will cancel the temporary timer setting and pressing it again will resume time clock operation.

Service Engineers

Pressing OPTION will allow you to interrogate the various temperature sensors in the indoor and outdoor unit by scrolling through them using the TEMPERATURE UP & DOWN buttons. The sensor reference is shown in the Error Display Segment. PC01 is the indoor unit air temperature sensor, PC02 is the indoor pipe temperature sensor, PC04 is not used and always shows 0, PC05 is the outdoor coil temperature sensor and PC07 the compressor discharge sensor.

Pressing and holding OPTION will allow you to enter Engineer Setup mode. Details are available in the Service Manual. Parameters in the Engineer Setup mode should only be changed by suitably qualified personnel with a copy of the Service Manual to hand. If you enter Engineer Setup mode by mistake press RESET to leave without changing any important system parameters.

Air Direction

The unit has four air outlets, each of which has a direction louver. These are linked and operate together—they cannot be operated individually. They are operated by the SWING button on the controller when the fan is operating. Press to start and press again to stop.

The louvers can be set to operate continually or set to supply air in a direction and then stopped. We recommend, for your best comfort, setting these in a direction which is comfortable and leaving them there. Our recommendations are shown below.

IMPORTANT—Do not attempt to operate the swing louvers by hand or damage to the mechanism may result.

Cooling—As cold air falls, best results in cooling come from setting the louvers to direct the air horizontally across the ceiling



Heating—As hot air rises, best results in heating come from setting the louvers to direct the air down toward the floor

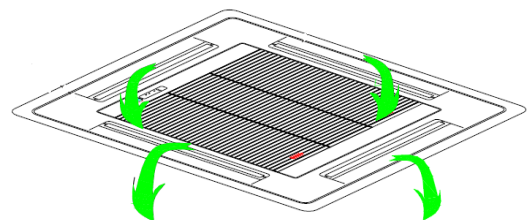
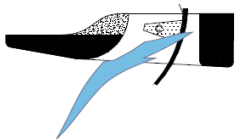

Service & Maintenance

Check Prior to Use

- The Earth wire is securely connected and not broken
- The Air Filter is clean and installed correctly
- The air inlet and outlet of both indoor and outdoor units are not obstructed
- Electrical power is present, securely connected and power has been supplied to the system for 8 hours

Optimal Operation

To get the most from your Highcool air conditioner pay attention to the following

1. During cooling operation avoid excessive energy consumption by using blinds to limit solar radiation and check to ensure the no heating system is operating as well as the air conditioner
2. Close doors and windows to avoid excessive heat gains or losses to the room
3. Ensure the room is adequately ventilated
4. Ensure no objects are placed in a position where they obstruct the airflow of indoor or outdoor units
5. Clean the Air Filter regularly. This is vitally important for correct operation of your unit
6. Keep the room clean. Dust and dirt will clog the air filter and cause the unit to emit odours
7. Do not operate the unit when the room is excessively humid
8. A comfortable temperature is between 22 & 24C. Setting the temperature too low or too high will increase energy consumption, be uncomfortable and may cause the unit to malfunction

Please note the operating conditions for this unit

	Cooling	Heating	Dehumidification	Automatic
Indoor Temperature	18C to 32C	15C to 27C	18C to 32C	18C to 27C
Outdoor Temperature	-15C to 43C	-15C to 24C	-15C to 43C	-15C to 24C/43C

- Please be aware that, in cooling, dehumidification or automatic operation, these are guidelines assuming average humidity conditions. Low humidity will increase the minimum indoor temperature and high humidity decrease the maximum indoor temperature in cooling. For this reason we do not suggest operating the air conditioner for long periods with a room temperature of less than 21C or more than 27C in cooling or these modes.
- Operating the unit for short periods on start up with the temperature below the minimum permissible indoor temperature in heating is allowed but prolonged operation at this level will cause malfunction.
- These conditions assume high fan speed. The minimum room temperature in cooling, dehumidification or automatic modes will increase and maximum room temperature in heating or automatic will decrease if automatic, low or medium fan speed is selected.
- Excessively high humidity will cause water droplets to form on the air outlets and louvers. Select high fan speed to alleviate this.



WARNING

Prior to commencing Service, Maintenance or Cleaning, run the unit for a short time in fan only mode with a high speed fan setting then turn the unit off and disconnect the electrical power.

In the event of the following conditions switch off the power supply and contact your service contractor for immediate investigation

- Repeated Minor Fault Codes or any Major Fault Code
 - Frequently tripping fuses or MCBs
 - Indoor or Outdoor Unit giving loud abnormal noises
 - Excessive Vibration or signs that the unit is not held firmly in position
 - Water Leakage
 - Less than 10C difference between supply and return air temperature in cooling or heating
 - Other Abnormal Conditions
-

Cleaning the Air Filter

Regular cleaning of the air filter is vital for correct operation of your air conditioner. Failure to do this will result in loss of performance, malfunction and eventual component failure.

To Clean the Air Filter

1. Press the two access buttons located on the underside of the cassette grille
2. Swing the access panel down so it hangs at around 90 degrees to the grille or remove completely
3. Remove the Air Filter from the grille and wash thoroughly
4. Dry the air Filter completely
5. Replace the Filter
6. Swing the access panel back into position ensuring it is securely fastened

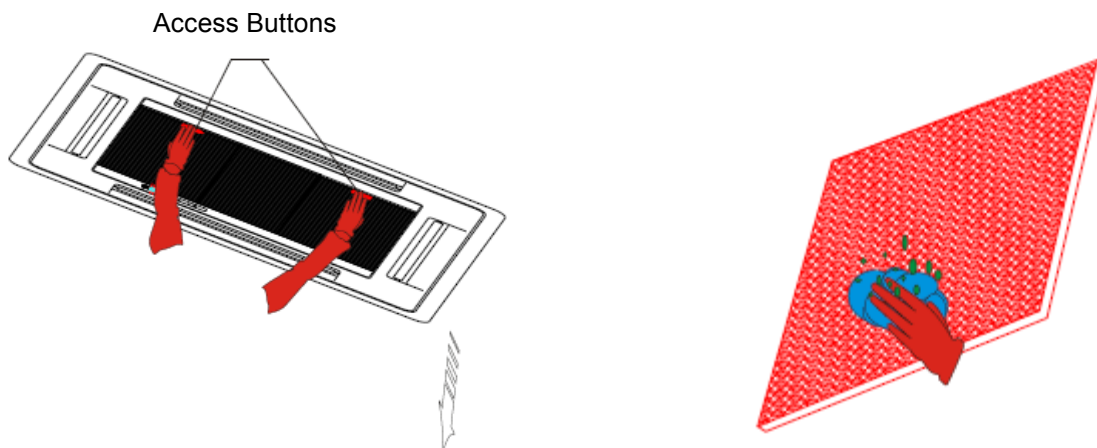

Fault Codes

In the event of a failure a fault code on the controller will usually advise the nature of the problem. Fault codes are divided into two groups. E codes are major faults and require the system to be manually reset. P codes are minor faults and will reset themselves in the event of the fault condition resolving itself. Sensor Failure P codes will allow the unit to run in emergency mode for 50 minutes with limited functionality before halting operation if the failure is not cleared.

All fault codes should be investigated by an engineer, although Pr03 and Pr08 should be investigated by the user by cleaning the filter and checking the operating temperature first.

Code	Reason	Initiation	Protection	Recovery
Eo00	ID to RC Comms Failure	Comms Fail	Sys Stop	Normal Comms
Eo03	Phase Lost or Swapped	Phase Problem	Sys Stop	Solve Problem
Er04	High Pressure Trip	>42 Bar	Sys Stop	<33 Bar
Er05	Low Press Trip	<1 Bar	Sys Stop	>3 Bar
Er06	High Discharge Temp	>120C	Sys Stop	Fix / Reset
Er07	Overcurrent Trip	ID Coil >16C	Sys Stop	Fix / Reset
Er08	ID to OD Comms Failure	Comms Fail	Sys Stop	Normal Comms
Er11	Drain Failure	Hi Water 30 mins	Sys Stop	Fix / Reset
Er12	Elec Heat Fail	Unused	Unused	Unused
Pr01	ID Pipe Sensor Fail	Short or Close	Emergency Run	Repair / Replace
Pr02	OD Pipe Sensor Fail	Short or Close	Emergency Run	Repair / Replace
Pr03	Cooling Mode De-ice	ID Coil <-2C/ 2 mins	Comp Off	EP01 + 14C
Pr04	Cooling Anti Overload	OD Coil >60C	Comp Off	OD Pipe <50C
Pr05	Discharge Sensor Fail	Short or Close	Emergency Run	Repair / Replace
Pr06	ID Air Sensor Fail	Short or Close	Emergency Run	Repair / Replace
Pr08	Heating Hi Temp	ID Coil >66C	OD off / ID Hi Spd	ID Coil <50C
Pr11	Drain Failure	Hi Water 30 secs	Comp Off	Auto Reset

Trouble Shooting

In the event of there not being a fault code present but the unit not performing correctly, the following checks can be carried out yourself.

Fault	Possible Cause	Solution
Unit will not switch on	Power Failure	Wait for resumption of power
	Power Switch Turned Off	Turn on power switch
	Tripped Fuse or MCB	Replace Fuse or Reset MCB
	Unit is off on timeclock	Manually Advance Timeclock
	Unit is off on remote Switch	Check condition of remote switch
Poor Cooling or Heating Performance	Improper temperature setting	Use correct temperature setting
	Dirty Air Filter	Clean the Air Filter
	Indoor or Outdoor air is restricted	Clear the obstruction
	Doors or windows are open	Close doors and windows
	Too high cooling or heating demand	Check for abnormal sources
No Cooling or Heating Performance	Blinds are open	Close the blinds
	Three minute protection device	Wait for 3 minutes
	Improper temperature setting	Reset the temperature setting
	Improper Mode setting	Reset the Mode



Warning—Do not attempt to repair the air conditioner yourself—call a professional
Warning—Do not use the mains switch to turn the unit on and off

Symptoms Not indicating a Fault Condition

The following symptoms do not indicate a fault

1. Compressor Protection—The compressor cannot operate for 3 minutes after it has stopped and will run for a minimum of 3 minutes once it has started.
2. Anti Draft Function—In heating mode the fan will not operate unless heat is being produced to avoid cold drafts.
3. Defrost Function—In heating the outdoor heat exchanger gets very cold and will build up ice. The defrost function operates to clear this. During defrost the symbol DEF is present on the controller, the indoor and outdoor fans stop and the compressor operates to remove any ice.
4. Mist may be produced from the air conditioner when the unit is cooling or dehumidifying during high humidity conditions or the unit commences heating after either cooling, dehumidification or defrost operation.
5. When the compressor is running or has just stopped operation you may hear glugging or whooshing sounds as refrigerant moves through the system.
6. When the system changes from cooling to heating or vice versa, or during defrost, a short whooshing sound may be heard.
7. When the unit is operating or has just ceased operation you may hear creaking due to the expansion or contraction of components
8. If the unit produces odours it can be because it has taken those odours in during operation, has untrapped drains or has a build up of bacteria inside it. Your service contractor can disinfect it for you if required.
9. No cooling or heating—when the unit has reached its set temperature cooling or heating will cease until it is required again.
10. If the unit operates in cooling, dehumidification or automatic modes in high humidity conditions water droplets may form on the air outlets. Run the fan at high speed to alleviate this.
11. Air outlet temperature is low in heating mode—During very low outdoor temperatures the amount of heat able to be produced is much lower and the air temperature leaving the unit will be lower than normal.
12. The outdoor fan slows down or stops—This is normal and happens in both cooling and heating modes to match the capacity of the outdoor heat exchanger with the capacity of the indoor.

Recommended Service & Maintenance Regime

The following is a list of the checks we recommend in order to get the best from your Highcool cassette system. This list is not exhaustive and many service companies follow a more rigorous schedule. We recommend taking out a service contract with the company who installed your Highcool system for you at the time of purchase.

Weekly Checks to carry out yourself

- Check the condition of the Air Filter and clean if necessary
- Check no visible interference of vandalism has occurred to any part of the system
- Check the unit is performing correctly in the mode required at that time. A thermometer will confirm this by measuring the temperature of the air going into the unit and the air coming out when the unit is cooling or heating—the temperature difference between the air in and out should be at least 10C.
- Check the unit is not making any unusual noises and there is no burning smell
- Contact the maintenance contractor immediately in the event of a failure or a fault condition

Quarterly Checks by the Maintenance Contractor

- Check the condition of the Air Filter. Clean or Replace if necessary
- Check for Vandalism, interference or wear and tear on any part of the system
- Check the cooling and heating performance of the unit. Investigate and repair if necessary
- Check the condition of the indoor and outdoor heat exchangers and drain pan. Clean if necessary
- Check for odours at the indoor unit. Treat the heat exchanger and drain pan if necessary
- Check that condensate is able to drain freely

Six Monthly Inspection by the Maintenance Contractor

- Carry out all of the checks for the quarterly schedule above
- Clean the Float Switch
- Clean the contacts of any temperature sensors
- Check PCBs for moisture damage
- Check and clean indoor and outdoor unit drain pans
- Clean the Return Air Grille of the indoor and outdoor units
- Clean the Indoor and Outdoor Heat Exchangers
- Check the electrical supply Voltage and also compressor running current

Twelve Monthly Service by the Maintenance Contractor

- Carry out all of the requirements of the six monthly inspection
- Check sensor resistances and make sure all are operating correctly
- Check drain hoses and condensate connections for signs of aging or cracks—replace if necessary
- Blow through drains to clear any debris. Ensure condensate can run freely
- Thoroughly clean all heat exchangers. Treat indoor coil and drain tray with bactericide
- Check for leaks in refrigerant circuit paying particular attention to flared joints. Repair if necessary.
- Check refrigerant and electrical circuits in all modes for correct performance
- Check electrical connections for corrosion and integrity. Remake if necessary
- Check PCBs for corrosion, dust or moisture damage. Clean or replace if necessary
- Check operation of indoor and outdoor fans
- Clean any attached ductwork and grilles
- Fully clean both indoor and outdoor units
- Lubricate the swing louver mechanism and ensure correct operation

Following this schedule will ensure many years of reliable operation and will protect your investment.

Please be aware that failure to have your Highcool unit maintained to this schedule may invalidate its warranty.

Installation

Before Installation please read all of the Safety Precautions

Please follow the instructions in this manual and any relevant local or national legislation

During Installation please follow industry 'Best Practice'

Please read the unit labels and this manual carefully before installation

WARNING

- The unit must be installed by a competent, trained and qualified engineer. Do not install yourself
- Any changes to the building structure required by the installation must comply with local and national legislation
- The indoor and outdoor unit must be fixed to structures that can support its operating weight
- Electrical cables must comply with both the instructions and IET regulations
- All electrical works must be carried out by qualified electricians
- Please ensure personal safety during installation including the use of Personal Safety Equipment
- Do not switch on the power supply until the installation is completed and checked
- Ensure adequate ventilation is available in case of refrigerant leakage
- After installation, ensure the end user is fully instructed in the use of their air conditioner and has a copy of all relevant user manuals to operate his air conditioner correctly and safely
- This unit must not be installed where volatile oils (including machine oil) or acidic gases are present as these will cause the unit to malfunction
- Ensure an Earth Leakage Circuit breaker is used
- Ensure the unit is correctly Earthed
- If the unit is installed on a metal part of a building, ensure good electrical insulation is provided complying with local and national standards and also 'best practice'

Selecting the Indoor Unit Location

Ensure the following conditions are satisfied and confirm the position with the customer



1. Ensure there is enough space to service and maintain the unit
2. Ensure a maintenance hatch is provided at the pipe connection side
3. Ensure the installation position is able to take four times the unit weight
4. The indoor unit must be away from sources of heat or steam and way from entrances
5. The indoor unit position must allow for easy drainage
6. The indoor unit position must allow for easy connection to the outdoor unit
7. The position must allow the air to not be obstructed
8. The position must allow the airflow to reach every part of the room
9. The indoor unit must be at least 3m away from any sources of electrical interference and cables should be run in steel conduit
10. If the unit is to be installed more than 3m high, select use the white HIGH fan speed connection plug in the indoor unit wiring loom in place of the red LOW speed connector installed at the factory.

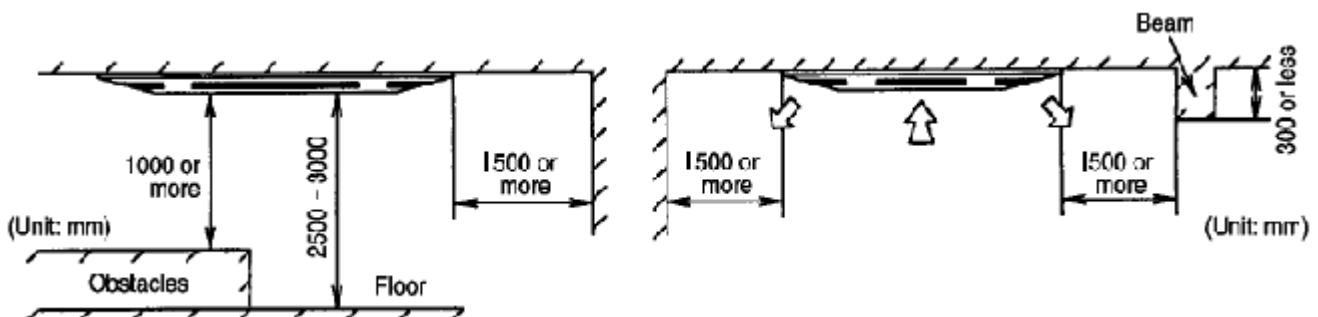

Selecting the outdoor unit location

Ensure the following conditions are satisfied and confirm the position with the customer

1. Ensure there is enough space for service and maintenance
2. Select a place where inlet and outlet are not obstructed and the unit is not subject to strong wind
3. Select a dry, well ventilated, place.
4. Select a place where the unit can be installed correctly, will support the units weight and will not transmit vibration.
5. Select a place where the operating noise of the outdoor unit will not affect neighbours
6. Ensure there are no gas pipes, flue pipes or potential flammable gas leaks nearby.
7. Select a place which allows for easy installation



Installation in the following places may cause malfunction, injury or death.

- Places with oil in the atmosphere
- By the sea or where the atmosphere contains salt
- In hot spring or other areas where there are acidic gases
- In automobiles or cabins where there is the risk of serious vibration or shock damage
- Places with strong electromagnetic radiation
- In kitchens or other places where there is steam, gas or oil in the atmosphere
- Places where acidic or alkaline liquids evaporate
- Explosive environments

Required for Installation

The following are required for installing your Highcool air conditioner. Approved installation items for use with your Highcool system are available from Medal Aircon on 01743 466333.

- Four M10 bolts for suspending the indoor unit
- PVC drain pipe
- Refrigeration quality copper tube and insulation (we recommend 9mm wall Vidoflex)
- Vidoflex insulation tape
- Outdoor power cable and interconnecting cable
- Outdoor Unit Mounting Bracket or Mounting Feet
- Indoor Unit electrical isolation switch
- Outdoor Unit Mains Isolator
- Cable Tray
- Extra R410a refrigerant if pipe separation extends beyond 10 metres
- Oxygen Free Nitrogen with regulating valve and manifold

The following specialist tools will be required to complete the installation in addition to normal engineers tools

- Core drill
- Torque Drive Set
- Concentric Flaring Tool
- R410a Service Manifold with hoses
- Vacuum Pump with non return and shut off valves
- R410a Refrigerant Recovery Unit
- R410a Reclaim Cylinder
- Electronic Thermometer
- Electronic Thermo hygrometer
- Electronic Anemometer
- Electronic Multimeter and Clamp Tester
- R410a refrigerant comparator
- Electronic Vacuum Gauge

Installing the Indoor Unit

The dimensions in mm required for installation of the indoor unit are shown below -

Model	SC187	SC247	SC427
Indoor Unit Height	255	240	280
Minimum Ceiling Height	310	295	295
Suspension Hook Height	175	150	150
Indoor Unit Body Size	570 x 570	840 x 840	840 x 840
Suspension Hook Centres	400 x 600	680 x 780	680 x 780
Ceiling Opening Size	620 x 620	900 x 900	900 x 900
Grille Size	650 x 650	950 x 950	950 x 950

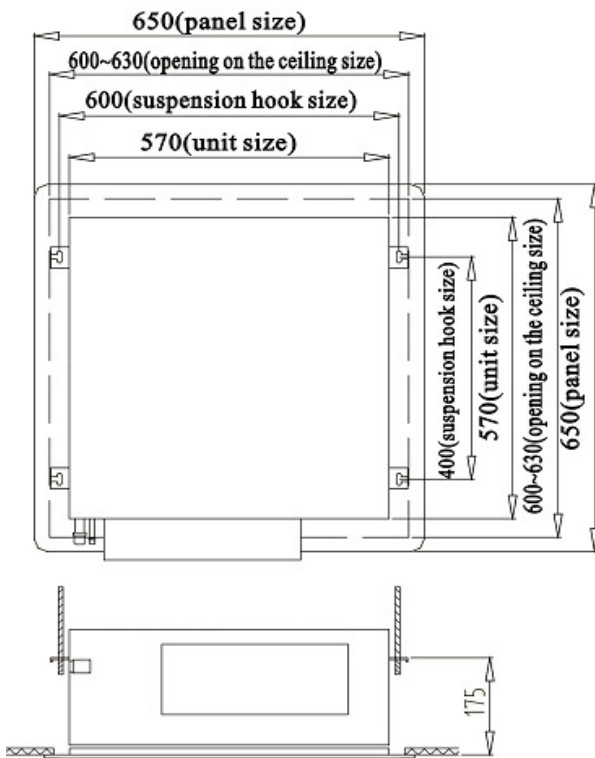

SC187

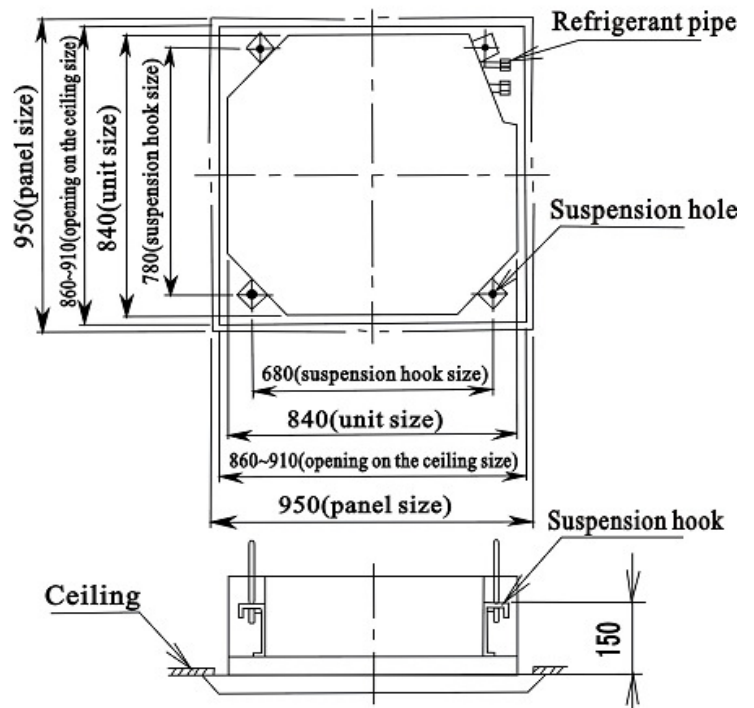

SC247 & SC427

See the diagram on page 18 for installation spaces required. In addition please allow at least -

- 1500mm from the grille centre to the nearest light fitting
- 2000mm from the grille centre to an extract duct or extract fan
- 4000mm from the grille centre to another cassette unit

Suspending the Indoor Unit

The suspension structure must be firm, reliable and capable of suspending at least 200kg.

It must be capable of resisting vibration and able to maintain its structural integrity for the lifetime of the units installation.

Fix the unit directly to the ceiling as shown or install additional brackets and hang the unit from these.

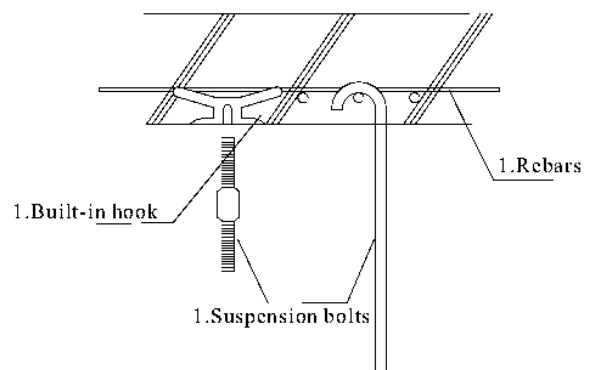

Sloping Ceiling

If the unit is mounted in a sloping suspended ceiling then the unit must be installed level and a gasket installed between the exposed cassette body and the grille as shown below

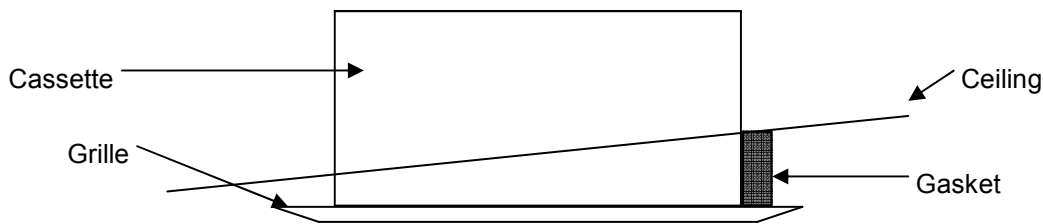

Mounting the Indoor Unit

1. Adjust the relative positions of the suspension hooks to ensure the indoor unit is level in all directions. Use a spirit level to ensure this.
2. Tighten the nuts and ensure that the hooks are tightly connected to the nuts and shims
3. Ensure the unit is tightly secured
4. Ensure the centre of the unit is at the centre of the hole in the ceiling

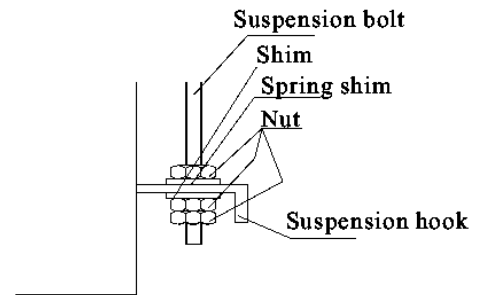

Drain Pipe Installation

Drain pipe work can be run in either hard Polyvinyl pipe type VP25 connected directly to the unit drain connector or the accessory drain tube used to connect to flexible hose of ID 16mm. Either way follow the regulations below.

1. Thermal insulation is recommended for the drain pipe work to avoid moisture forming on the outside.
2. Pipes should be run in a straight line with a 1/50 to 1/100 slope to allow the water to drain away. The pipe should not rise at any point.
3. It is permissible to raise the height of the drain pipe to up to 750mm from the false ceiling provided this is done within 300mm of the unit.
4. When connecting the drain pipes from multiple units the common drain must be at least 100mm below each units drain outlet.
5. The drain pipe should be supported every metre of its length.

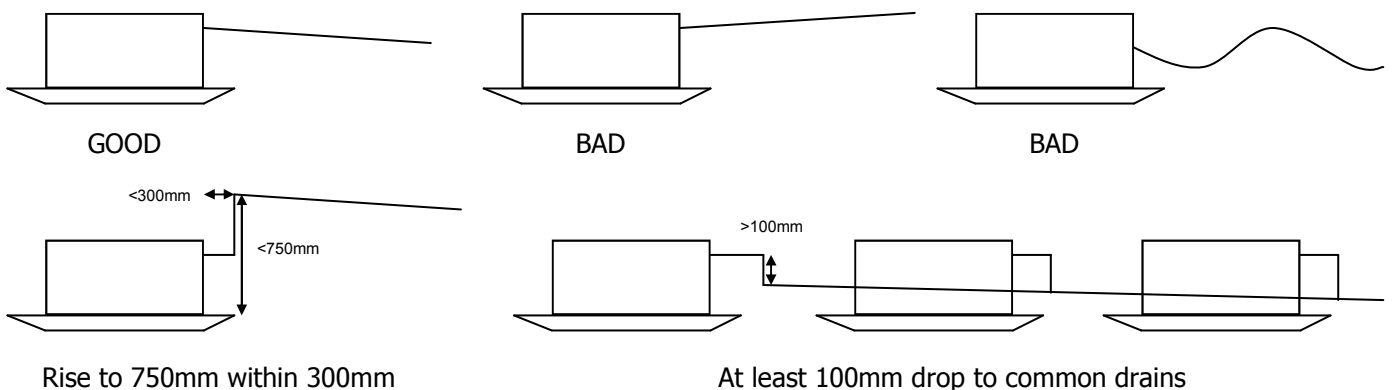

Installing the Return Air Grille

Three models of return air grille are available. The SG187 grille is used with indoor unit SC187, SG247 is used with SC247 and SG427 is used with SC427. Grilles SG247 and SG427 are physically identical.

The smaller SG187 is much easier to lift than the larger SG247 and SG427. For this reason the larger size grilles are equipped with suspension hooks.

Installation of the grille involves the following -

1. Remove the centre filter access panel and any corner access panels
2. Locate the swing louver control cable on one corner of the grille—this corner should be installed at the corner of the unit where the refrigerant pipe work connections are.
3. For model SG187 offer up the grille to the unit and fix using the four mounting bolts
4. For models SG247 and SG427 offer up the grille to the unit and first connect the four guide hooks before fixing using the four mounting bolts
5. Replace the filter access panel and corner access panels

Connection of SG247 / SG427 is shown below

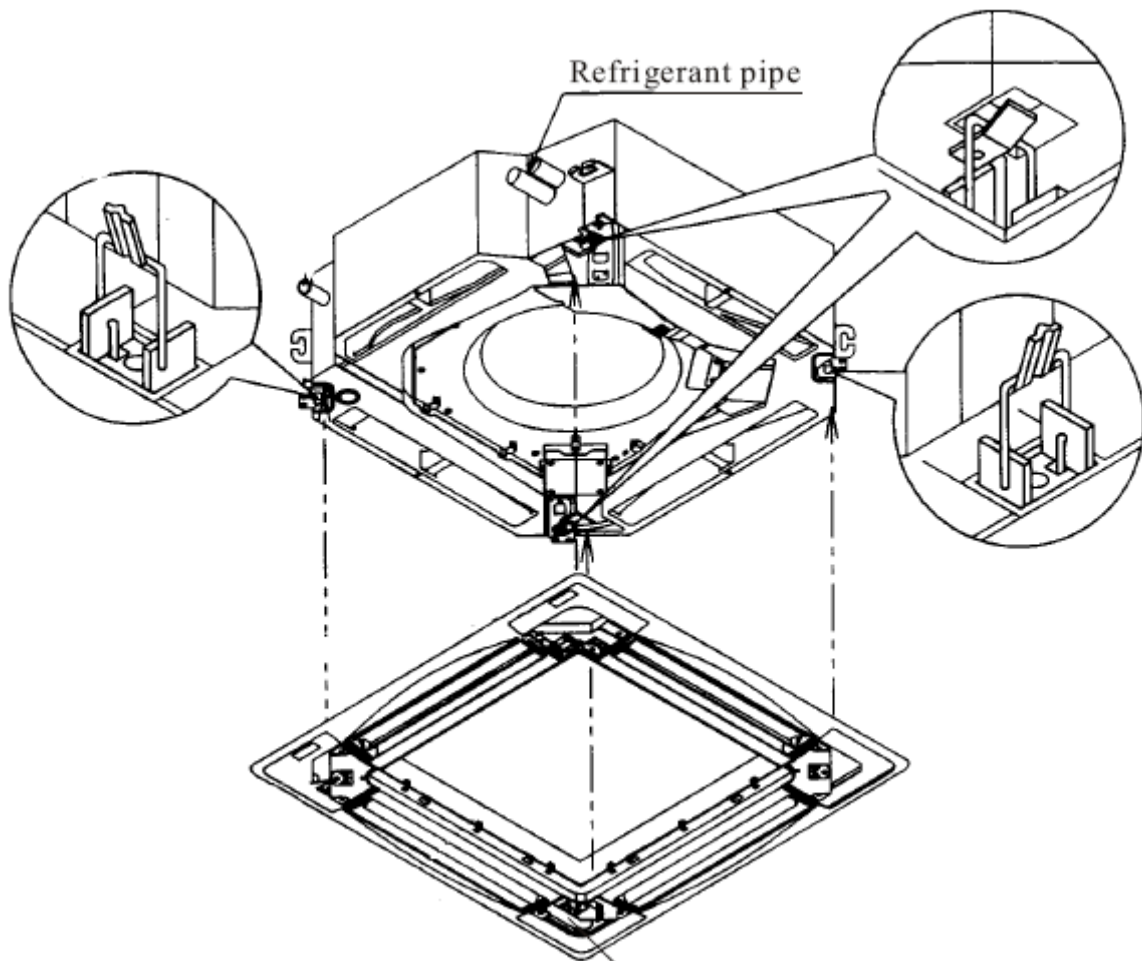

Installing the Outdoor Unit

Overall Dimensions (in millimetres)

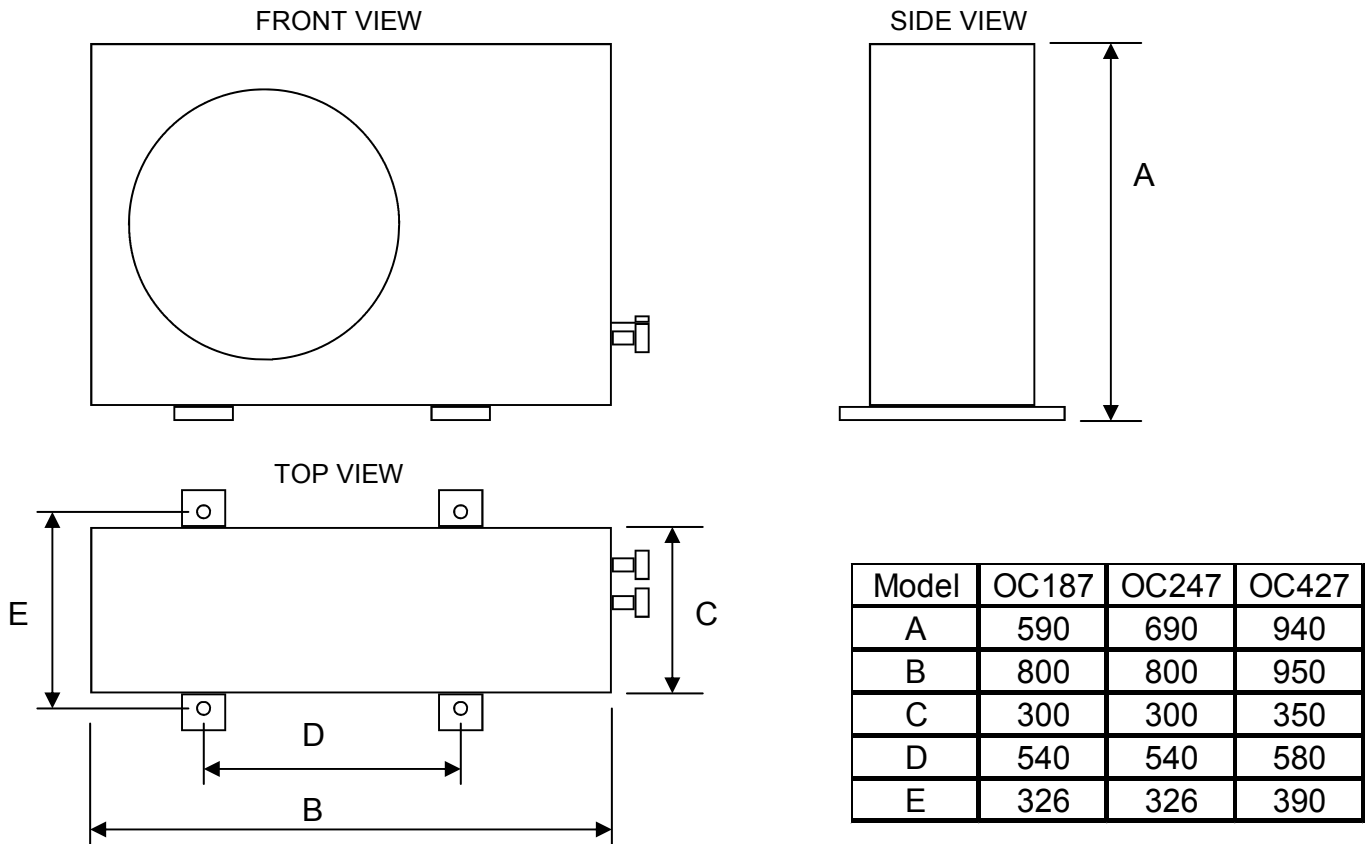

Installation Clearances (in millimetres)

Minimum allowed space between the unit and the nearest obstacle to allow for adequate airflow and maintenance access.

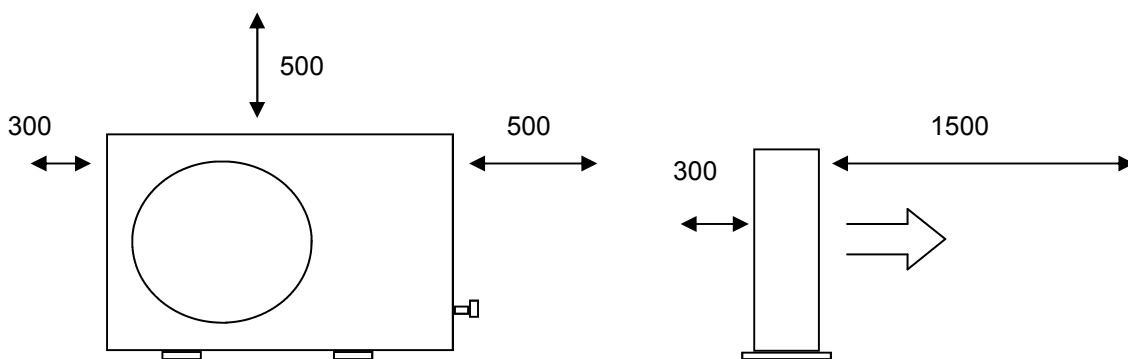

Positioning the Outdoor Unit

Very high or low temperatures will affect the performance of the unit

1. Ensure adequate airflow and avoid air recirculation
2. Ensure adequate drainage from the outdoor unit
3. Check the unit is level. A slope of 5 degrees or more can cause malfunction or failure.
4. Ensure the unit is adequately secured
5. Do not allow the air from one outdoor unit blow directly onto another

Lifting the Outdoor Unit

Use two slings to lift the unit.
Use spacers to protect the surface and heat exchangers of the unit.



WARNING

Avoid contact with the heat exchanger surface.
Sharp fins can cause injury

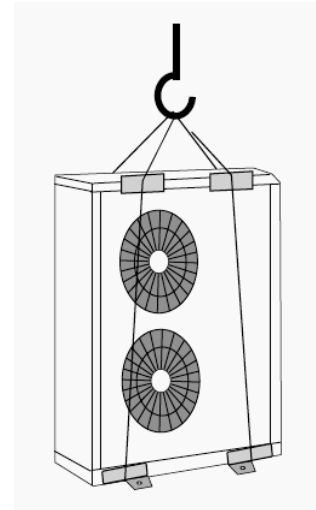

Installation of the Outdoor Unit

1. Use the drain connector provided with the unit to connect drain pipe work. Ensure adequate drainage.
2. Ensure the unit is secured properly and free from vibration
3. Ensure the unit is bolted down correctly and the surface it is attached to is secure and stable
4. We recommend using plastic mounting feet for floor mounted installations
5. We recommend using wall brackets for wall mounted installations
6. Use protective cages to protect the unit from damage and passers by from harm when mounting the unit in a public space.
7. If mounting on the floor where no firm surface is available, create a concrete base or use paving slabs to create one.
8. Ensure mounting bolts protrude upward for at least 20mm



CAUTION

Ensure adequate drainage. The outdoor unit will produce water. If drain pipe work is not used then utilise a drainage ditch or other method of removing condensate water.



NOTICE

- The installation position must be well ventilated to ensure correct operation
- The installation position must be firm enough to take the weight of the unit and absorb any vibration
- The installation position must be adequately drained so rain and condensate water does not accumulate
- The installation position must not be subject to becoming immersed in snow
- The air outlet must not point in the direction of strong winds
- The installation position must not be subject to accumulation of rubbish or airborne contaminants

Examples of Correct and Incorrect Installation

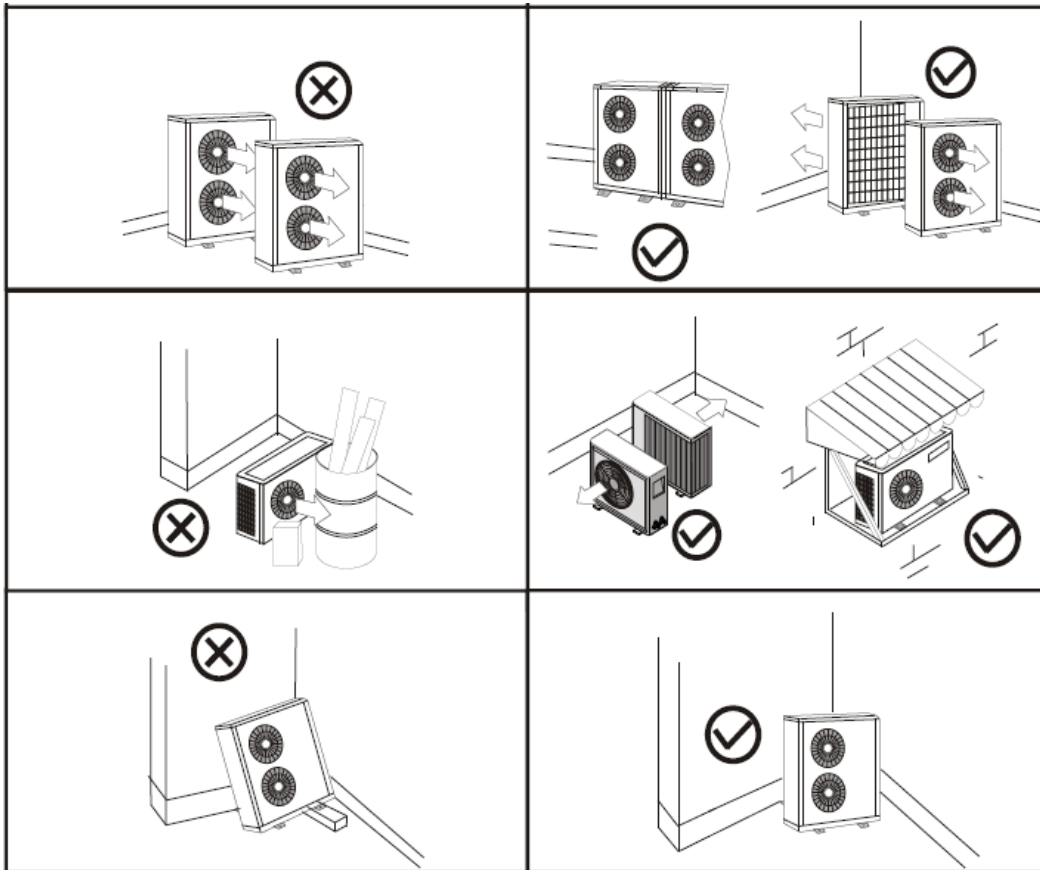

Refrigerant Pipe work

The indoor and outdoor unit are connected by refrigerant pipe work. Special refrigeration quality dehydrated copper pipe must be used and this must be insulated to prevent heat loss and condensation.

Uninsulated soft drawn copper pipe is stocked at all branches of Climate Center nationwide in handy 15 metre and 30 metre coils with separate Armacell Armaflex 9mm wall insulation material available in 2m lengths and longer boxed coils. Pre insulated Armacell Duosplit copper is also available in 20 metre lengths. Always use genuine Climate Center pipe & insulation.

Limitations of Refrigerant Pipe work

The table below shows the maximum pipe separation and vertical lift and also the maximum number of bends for your Highcool air conditioner. Always keep pipe separation and the number of bends to a minimum.

System		SC187	SC247	SC427
Pipe Size	Liquid	1/4"	3/8"	3/8"
	Gas	1/2"	5/8"	3/4"
Max Length (m)		25	25	50
Max Height (m)		10	10	20
Max Bend Qty		6	8	10

Making the pipe work correctly



It is essential for the correct operation of your unit that the pipe work is correctly installed and connected and is of the correct type and size and that the work follows the design guide lines and limitations in this manual. Failure to do so will result in malfunction, failure, refrigerant gas leaks and possible hazard to health.



Handling Refrigerant Pipe

It is essential when handling refrigerant pipe that moisture or air do not enter the tube. Pipe is sold 'capped' to prevent this and when the tube is open to atmosphere for more than a few seconds it must be either recapped or otherwise resealed. Never allow water to enter the tube or store where water can collect. Pay particular attention with any vertical pipes because of the potential for rain, dust and other contaminants to enter the pipe work. Always purge pipes that have been open for more than a few seconds with OFN (Oxygen Free Nitrogen).

Tube that is to be left unconnected for several weeks or more should be 'pinched off' and brazed shut to prevent contamination. For lesser periods PVC tape may be used to secure the cap that covered the pipe work when purchased or used as below to secure the pipe.

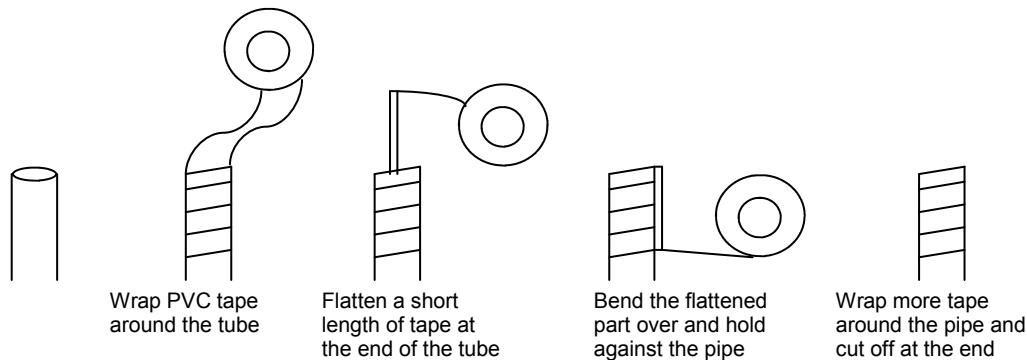

Bending the Tube

It is essential that any bends in the pipe offer as little resistance to refrigerant flow as possible. Bends should be as wide as practical and there should never be more bends than the quantity allowed in the chart on page 25. Always use a bending machine or bending spring to make any bends.

Brazing

Do Not braze pipe if unqualified and untrained to do so. Do not use soft solder and always bleed Oxygen Free Nitrogen through any pipe being brazed to avoid oxidation. In most cases brazing should be unnecessary to install a Highcool cassette system. Always use Oxyacetylene or similar systems to ensure a hot enough flame.

Due to the dangers inherent in brazing we cannot give any advice which may be used by unqualified personnel. The Vilkan Lokring jointing system should be considered for joining pipes in place of brazing in places where hot works are not permitted or where staff are untrained in brazing pipe.

Cutting Copper Tube

Never use a hacksaw to cut refrigerant copper tube. Always use a purpose designed copper tube cutter and ensure it is properly deburred afterwards. Your local Climate Center carries these in stock as well as spare blades and tools for deburring. Ensure the blade is sharp.

Connections at Indoor and Outdoor

Your Highcool system is provided with flared connections at both the indoor and outdoor unit. Flaring is a reliable and safe method of connection provided it is carried out correctly by trained and qualified professionals.

CAUTION

The refrigerant used in this system (R410a) runs at extremely high pressures (Up to 42 Bar or 610 Psi). Conventional flaring kits will not give satisfactory results with this refrigerant and specially designed products designed for use with R410a are available at your local branch of Climate Center. We particularly recommend the 689646 concentric flaring tool.

Always use a torque wrench (we recommend model 688507) when connecting flare nuts to their joints. Always use a spanner to hold the joint steady while connecting the flare nut with the torque wrench. Before making the flare on the copper tube ensure the flare nut has been slid onto the tube first as this cannot be done afterward. Always use a little refrigerant oil to coat the inside and outside of your flare. Always check the pipe is cut correctly first.

The following table shows the required tightening torque and machining dimensions for each size of copper pipe.

Pipe	Dia mm	Torque Nm	Dim A mm
1/4"	6.35	15 to 19	9.10
3/8"	9.52	35 to 40	13.20
1/2"	12.70	50 to 60	16.60
5/8"	15.88	62 to 76	20.00
3/4"	19.05	98 to 120	24.00

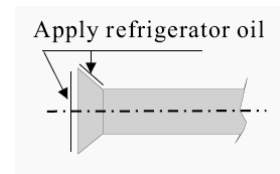
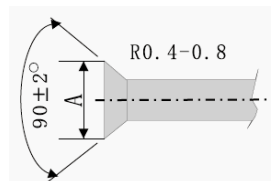

Good and Bad Cuts

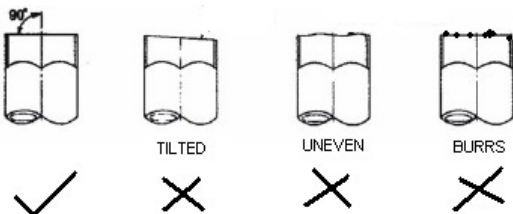

Bad Flares

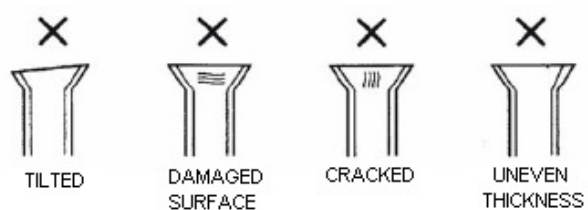

Always

Leave the pipes capped until the last moment. Bleed OFN through any open pipes. As soon as the pipe work has been completed purge and then pressurise the system with OFN prior to the leak test.

Piping between the Indoor and Outdoor Unit

When forming the pipe work between the indoor and outdoor unit ensure that the limitations shown on the preceding pages are followed. Never exceed the maximum length or vertical lift and do not add these two figures together. Always ensure that moisture or air does not enter the pipes and that pipe ends are always capped when not being worked upon. This particularly applies when they are held upright and when passing through a wall.

Making the Connections

It is recommended that the suction (large) pipe at the outdoor unit is connected first. This allows an OFN (Oxygen Free Nitrogen) cylinder with appropriate manifold to be connected to the access port on the suction line service valve in order to pressurise the pipe with OFN or bleed nitrogen through gently if the pipe must be uncapped for any reason or brazing is taking place. Connect the suction (large) pipe to the indoor unit next, then the liquid (small) pipe to the indoor unit and finally purge the pipe work with OFN before connecting the liquid (small) pipe to the outdoor unit.

To make each connection remove the nut from the flare connector, slip this over the copper pipe and discard the copper bonnet on the flare connector. Use an R410a compatible flare tool to flare the copper pipe, lubricate the flare with refrigerant oil and tighten the flare nut back onto the flare connector. Always check the flare has been made correctly before connecting and always hold the flare connector firmly in place with a spanner while using a torque wrench to tighten the flare nut to the correct torque.

Once all pipes are in place and securely connected pressurize the whole system with OFN as soon as possible. Ensure all pipes and connectors, except service valves, are insulated.

Pressure Testing, Evacuating and Charging



This process in particular should only be attempted by trained and qualified professionals. Working with high pressure gases is hazardous and should not be attempted by anyone not fully conversant with the dangers involved and wearing personal safety equipment.

- Failure to leak test adequately can lead to loss of refrigerant, danger to health and potential prosecution.
- Failure to remove contaminants can cause malfunction and high system running pressures
- Failure to charge system correctly will cause incorrect performance and may cause malfunction or failure

Pressure and Leak Testing

Before charging with refrigerant pressure test the pipe work and indoor heat exchanger for integrity & leaks with OFN (Oxygen Free Nitrogen). Ensure that the two service valves are fully shut and only increase OFN pressure gradually to avoid nitrogen passing through the service valves and contaminating the refrigerant.

1. Pressurise to 3 Bar (42psi) to find large leaks
2. Pressurise to 15 Bar (213psi) to find small leaks
3. Pressurise to 28 Bar (398psi) to find very small leaks and perform full system pressure test. We recommend testing for 24 hours at this pressure.

Repair any leaks at once and then restart the test process until you are sure that the system is fully gas tight and secure.

Evacuation Process

The presence of moisture or air in the pipe work will cause malfunction or failure to your system and must be removed thoroughly before the valves can be opened and your system operated. Using an accurate electronic vacuum gauge to monitor this process and then test the state of vacuum will ensure that this is done quickly and accurately.

1. Release all OFN from system
2. Connect Vacuum Pump to Manifold & turn on
3. Connect Low pressure manifold line to unit service valve
4. Open low pressure manifold valve
5. Connect Vacuum Gauge to high pressure manifold line
6. Open high pressure manifold valve
7. Turn Vacuum Gauge on and monitor process
8. Once 700 micron (0.7 Torr) is reached isolate vacuum pump and turn off
9. Evacuation is complete if the vacuum holds under 1000 micron (1 Torr) for 1 hour.

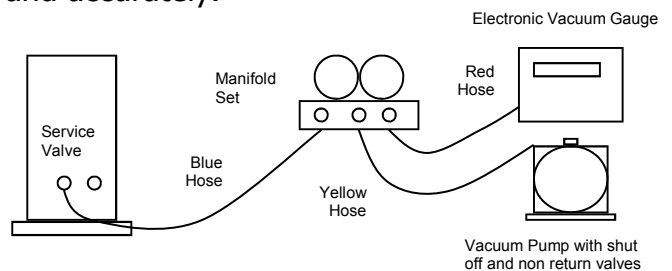

To speed up the evacuation process, if it is taking a long time, halt the evacuation process and purge with OFN, ensuring the vacuum pump and gauge are isolated. Failure to hold below 2000 micron (2 torr) indicates a leak or water. Failure to hold between 1000 & 2000 micron (1 & 2 Torr) indicates the presence of moisture. Shut off the high pressure manifold valve and remove the Vacuum Gauge after evacuation is complete.

Charging with Refrigerant



WARNING

Wear gloves and eye protection at all times during the handling of refrigerant due to the danger of frost bite and pressurised gas release. Never vent refrigerant or allow it to escape to atmosphere. Always catalogue your use of refrigerant as evidence that leakage or venting has not taken place in case of prosecution. Ensure the workplace is well ventilated to avoid asphyxiation in the event of a leak.

Once the system has been evacuated and can hold below 1000 micron (1 Torr) for an hour the system can be charged.

Your Highcool cassette system is delivered with sufficient refrigerant R410a for a 10 metre pipe length from the outdoor to the indoor unit.

- If the pipe length is less than this then no additional charging is necessary. The two service valves on the outdoor unit can be opened to release the refrigerant and the caps tightly replaced. Your system is now charged.
- If the pipe length is less than 3 metres then additional pipe must be installed and looped within the false ceiling or the unit will be overcharged.
- If the pipe length is greater than 10 metres then additional refrigerant must be weighed into the evacuated pipe work.



CAUTION

- Always weigh the refrigerant accurately. Do not guess or charge by pressure.
- Do not use the compressor to pump the refrigerant in. Always decant the refrigerant into the evacuated pipe work.
- Ensure the gas bottle is situated so charging is with liquid refrigerant not gas.
- Ensure the bottle is high enough so liquid refrigerant can be decanted into the pipe.

The table on the right shows the Charging Data for your unit. Do not exceed the Maximum pipe run or charge.

Model	SC187	SC247	SC427
Base Charge (g)	1500	2300	3000
Charged For (m)	10	10	10
Extra R410a per m (g)	20	50	70
Maximum Run (m)	25	30	50
Maximum Extra (g)	300	1000	2800
Maximum Charge (g)	1800	3300	5800

The charging process is shown below.

1. Place the cylinder on the scales safely and securely in a position that allows for decanting
2. Disconnect the yellow charging hose from the vacuum pump
3. Connect the charging hose of the manifold to the cylinder
4. Purge any air from the hose
5. Open the low pressure manifold valve and watch the scales
6. Add the required quantity of refrigerant to the system
7. Shut off the low pressure manifold valve
8. Shut off the R410a cylinder, disconnect and remove.
9. Open both system service valves & replace the caps tightly.
10. Mark the extra R410a added on the unit nameplate

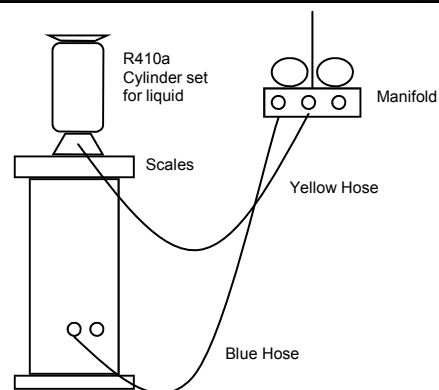

The system is now charged with refrigerant.

Before operating the system remove the blue low pressure manifold hose and replace it with the red high pressure hose. Never operate the system with the low pressure manifold gauge in case the system starts to operate in heating as this will damage the low pressure gauge.

Electrical Wiring



WARNING

- All electrical works must be carried out & checked by a qualified electrician and must adhere to the IET regulations, local and national legislation and industry 'best practice'.
- Check to ensure the power supply meets the requirements of your unit, is stable and (for model SC427) all three phases are balanced correctly.
- The power supply to your air conditioner should have its own, unique, power circuit.
- All wiring should be secured correctly and each cable should not touch one another.
- The system should be correctly fused and Earth Leakage circuit breakers should be used.
- A method of switching the mains supply off should be within reach of both indoor and outdoor unit.
- Both indoor and outdoor unit contain a control PCB with a fuse. The specification of this fuse is 5x20 TSD 3.15A/250V
- If Steel Wire Armoured (SWA) cable is used then it must be correctly glanded.
- Control (Low Voltage) cable should be run separately to the mains cable and be routed so exposure to High Voltage cable and electromagnetic radiation is avoided.
- If shielded cable is used for the Control cable then the shielding should be earthed at the outdoor unit only. Do NOT earth at both ends.

Electrical Connections

Models SC187/OC187 & SC247/OC247

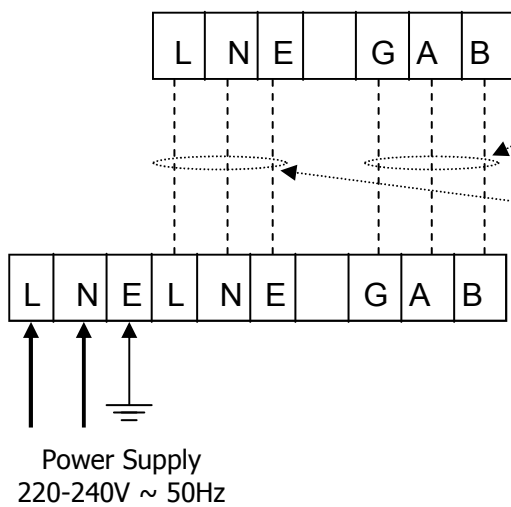

Model SC427/OC427

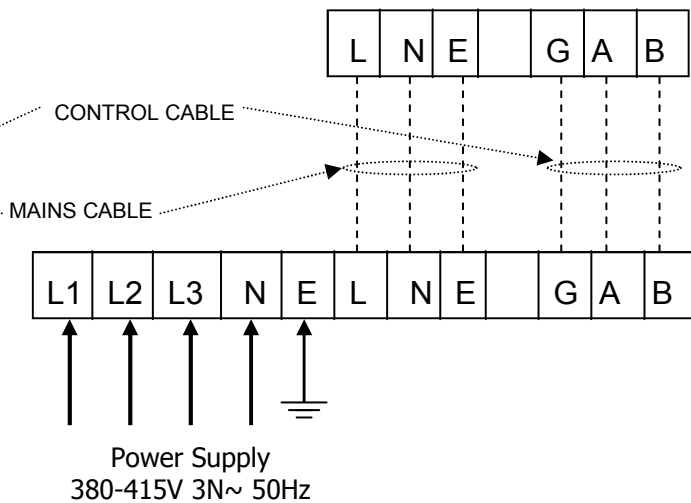

Model Ref SC/OC		187	247	427
Power Supply	mm ²	3 X 4.0	3 X 6.0	5 X 4.0
	Phase	1	1	3 + N
Connecting Cable	Mains mm ²	3 X 1.5	3 X 1.5	3 X 1.5
	Control mm ²	3 X 1.0	3 X 1.0	3 X 1.0
Fuse (Slow Blow)		20A	32A	20A

Usual Cable Types

- Power Cable H05RN-F or SWA
- Mains Connecting H05VV-F or SY flex
- Control Connecting H05VV-F or CY flex

Control Cable run in CY flex should have the shielding earthed at the outdoor end only. Do NOT earth at both ends.

All the above along with all electrical accessories are available at your local branch of Electric Center.

To maintain electrical connection integrity ALWAYS use crimped connections both indoors and outdoors rather than bare wires.

Power Cable sizes are given as a guide only and may vary with distance. Please check yourself to be sure.

Electrical Connections at the Indoor & Outdoor Units

CAUTION

- Ensure that the power cable to the outdoor unit is supplied via a weatherproof mains isolator mounted within arms reach of the electrical panel of the outdoor unit so it can be turned off in case of an accident or emergency.
- Ensure that the mains interconnecting cable is taken through an isolating switch mounted within arms reach of the electrical panel of the indoor unit so it can be turned off in the case of an accident or emergency.
- Ensure that the mains interconnecting cable is not connected inadvertently to the control cable terminals (marked G, A & B) or expensive damage may be caused to the indoor and outdoor PCBs and controller.

To connect the Indoor Unit

1. Open the cover of the Terminal Box
2. Use the straps provided to secure the mains and control connecting cables
3. Connect the Control Cable to the Control Cable terminals
4. Connect the Mains Cable to the Mains Cable Terminals
5. Check all cables are connected safely, securely and correctly
6. Close the Terminal Box

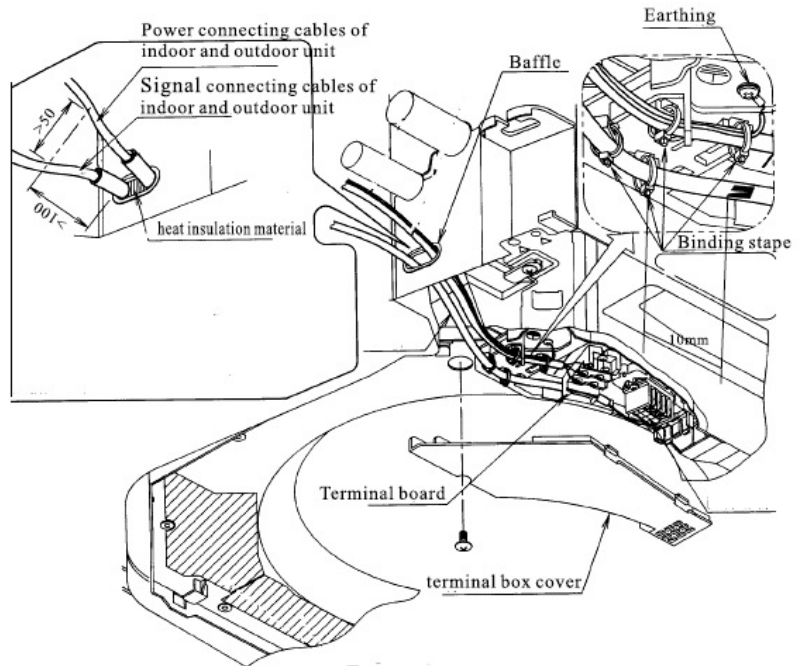

To Connect the Outdoor Unit

1. Open the outdoor unit electrical access panel
2. Use the straps provided to secure the Power, Mains Connecting and Control Cables
3. Connect the Control Cable to the Control Cable Terminals
4. Connect the Mains and Power Cable to their terminals
5. Check all cables are connected safely, securely and correctly
6. Close the electrical terminal box

Finishing Off

After all connections have been made and checked, the pipe work has been leak tested and charged and the drain pipe work tested then the pipes and cables should be bound together as follows

1. Locate the drain pipe at the bottom along with the control cable
2. Place the insulated refrigerant pipes on top
3. Place the mains cable on top of these
4. Bind carefully with tape
5. Ensure the drain pipe is not damaged
6. Take the drain to a safe drainage point

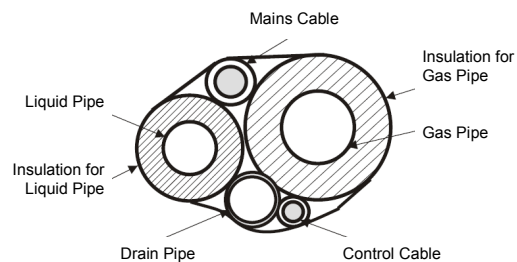

Fitting the Controller



CAUTION

- Use the screws provided with the controller to avoid damage to the casing
- When running the control cable avoid any High Voltage cables or sources of electromagnetic radiation
- Do not mount the controller near sources of steam or heat or where water can drip on it
- Do not mount the controller near radios, televisions or other electronic devices

The controller is provided with a connector and this connects to a factory supplied control cable which also connects to the indoor unit. Do not extend this cable.

1. Remove the controller from the back plate using the point of a small screwdriver
2. Locate the back plate on the wall and use the screws provided to fix it securely and level
3. Clip the controller back onto the back plate
4. Connect the controller to the control cable provided
5. Connect the other end of the control cable to the plug provided in the indoor unit
6. Enclose the control cable in trunking

Commissioning

1. Turn on the Power Supply and switch the mains isolators on indoors and out.
2. Check the LED on the controller is lit—it should glow red.
3. Press the Operation (On/Off) button on the controller. The LED on the controller should now glow green.
4. Select cooling operation on the controller and set the temperature to 16C and the fan to high speed
5. Wait for 5 minutes and check the controller. The pump, compressor and outdoor fan symbols should be displayed.
6. Press the SWING button and check the louver is operating. Set it in an appropriate position for the time of year using the SWING button.
7. Check the system is performing correctly in cooling with all indoor fan speed settings
8. Select Heating operation on the controller with a setting of 30C and the fan on high speed.
9. Wait for 5 minutes and check the controller. The compressor, outdoor fan and reversing valve symbols should be displayed.
10. Check the system is performing correctly in heating with all indoor fan speed settings
11. Check the drain operates correctly. If necessary introduce water into the indoor unit drain tray.
12. Check the outdoor drains operate correctly.
13. Program the date and time on the controller with the unit off
14. Agree start and stop times for each day for the time clock and whether the unit will run that day with the end user. Program these into the Controller and note them in the Controller Operation Manual
15. Instruct the End User in operation of the Controller and the air conditioner
16. Fill in the commissioning report on Page 43
17. Give this manual to the end user along with the Controller Manual

Thank you for installing Highcool air conditioners

Appendix 1—Fresh Air & Branch Ducts

Models SC247 and SC427 (but not SC187) are able to be connected to fresh air ducts in order to ventilate the room. They are also able to connect to short lengths of branch ductwork to take conditioned air into small separate rooms or give better air distribution in an awkwardly shaped room.

Fresh Air Ducts

The corner opposite the pipe entry has a 75mm knock out for introducing fresh air. This can be removed using a pair of snips and a 75mm or 100mm spigot connected to the side of the unit to allow a circular, insulated, fresh air duct to be connected to outside. While a very small quantity of fresh air will be induced using the cassettes own fan it is recommended that a separate fan is used to boost the airflow. This fan should have its own, separate, on/off switch.

Branch Ducts

There are four large rectangular branch duct knockouts, one on each side of the cassette. These knockouts are 405mm wide and either 95mm high (SC247) or 150mm high (SC427).

The knockouts may be removed using snips and the polystyrene casing behind cut with a knife. Spigot plates can then be connected to the side of the unit to allow ductwork to be connected and air to be ducted away. All ductwork should be thermally and acoustically insulated.

A maximum of 5 metres of duct is recommended.

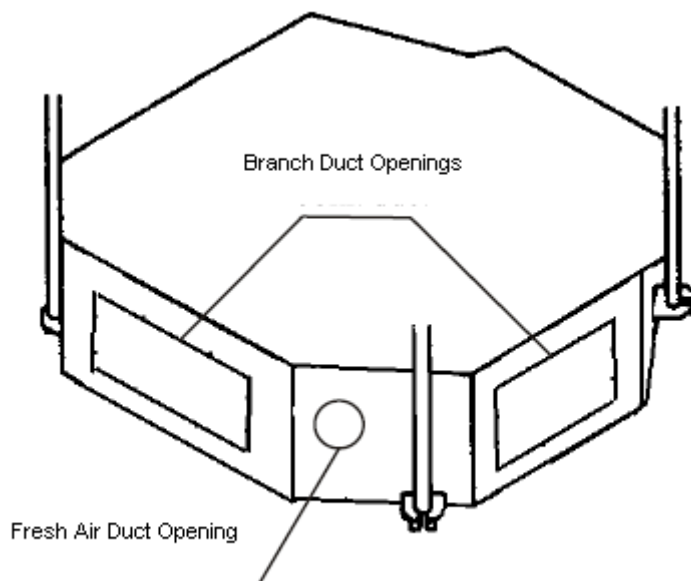

Appendix 2—External Interfaces

It is possible to operate the Unit remotely from an external control signal and also to send a signal to a remote panel in the event of a unit fault.

In both cases a two core signal cable, ideally 1mm CY type earthed at one end, is required.

Remote Operation

The Indoor control PCB has two spade terminals marked PCOM and ON / OFF. If operation feature SA10 is enabled (On) using the OPTION feature on the remote controller then bridging between these two terminals will cause the unit to run and breaking the bridge will cause the unit to start.

If SA10 is enabled but no connection is made externally then the unit cannot run. Only connecting between these two terminals will allow the unit to operate when SA10 is enabled.

Remote Fault Alarm

The indoor PCB has two spade terminals marked ALARM. Normally there is no continuity between these two terminals but in the event of a fault condition a relay operates to give continuity between these two terminals.

It is possible therefore to use a maximum 240V feed to one side of the ALARM terminals to give a fault signal from the other side. It is recommended that a low Voltage (12V or 24V) is used and this signal is only designed to operate a control signal (operating a relay).

Indoor PCB Layout

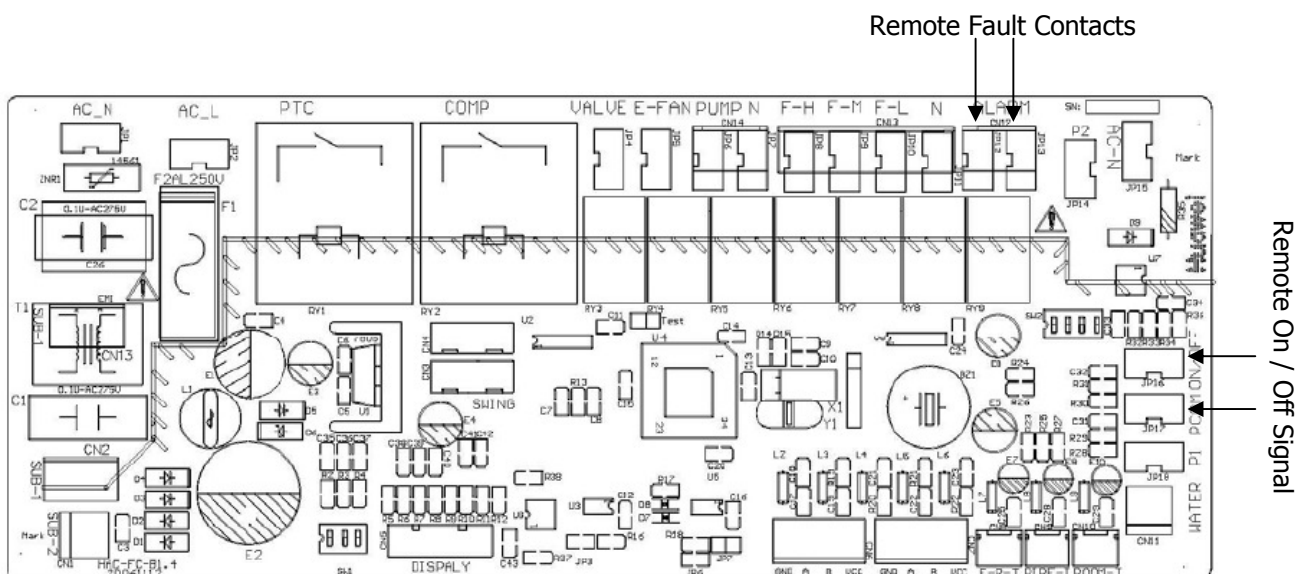

Appendix 3—Indoor Unit Wiring Diagrams

SC187

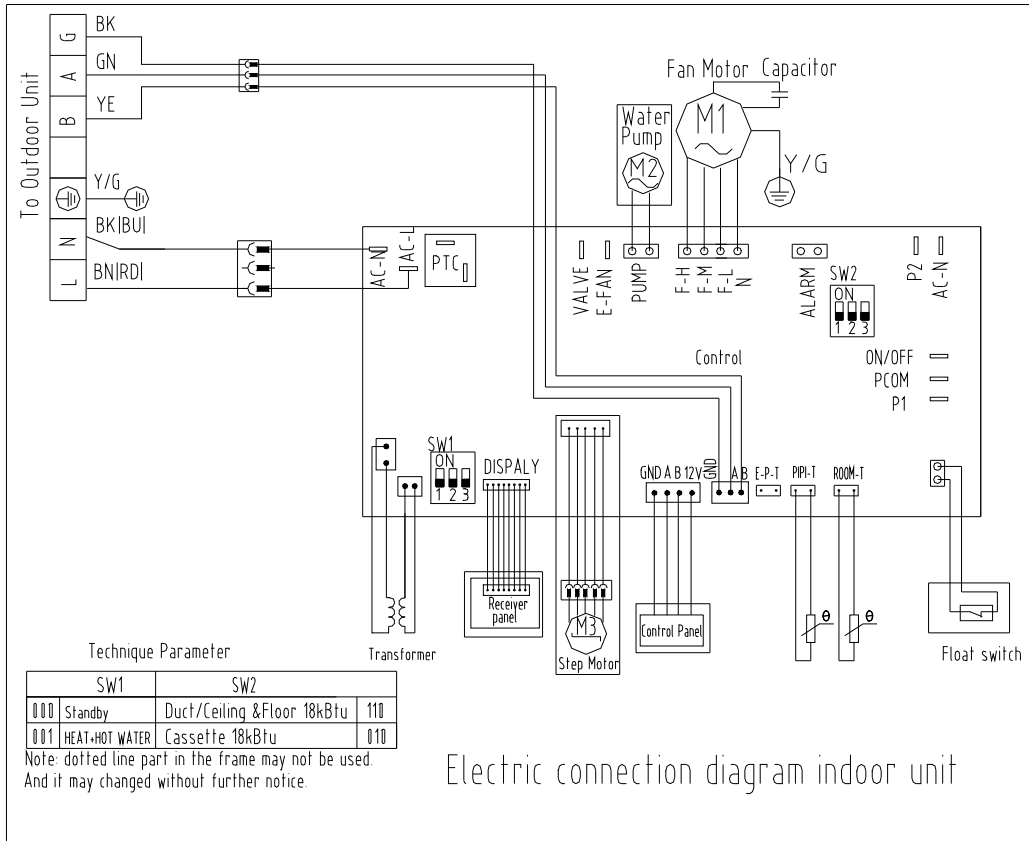

SC247 & SC427

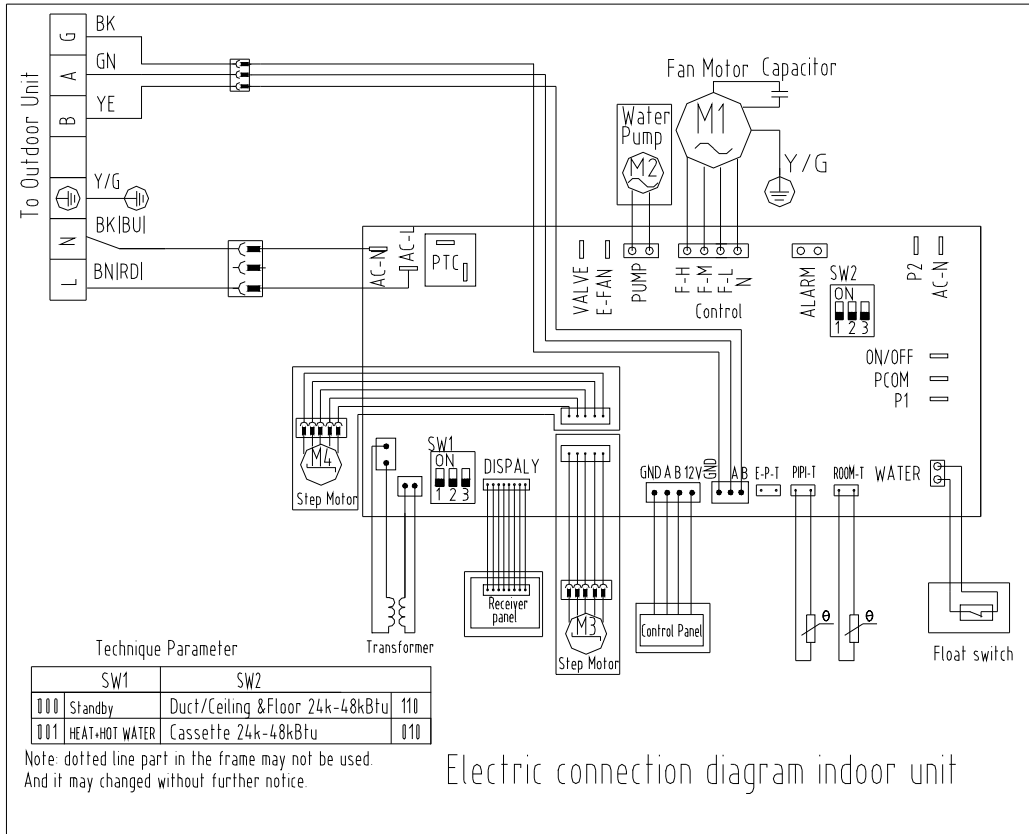

Appendix 4—Outdoor Unit Wiring Diagrams

OC187 & OC247

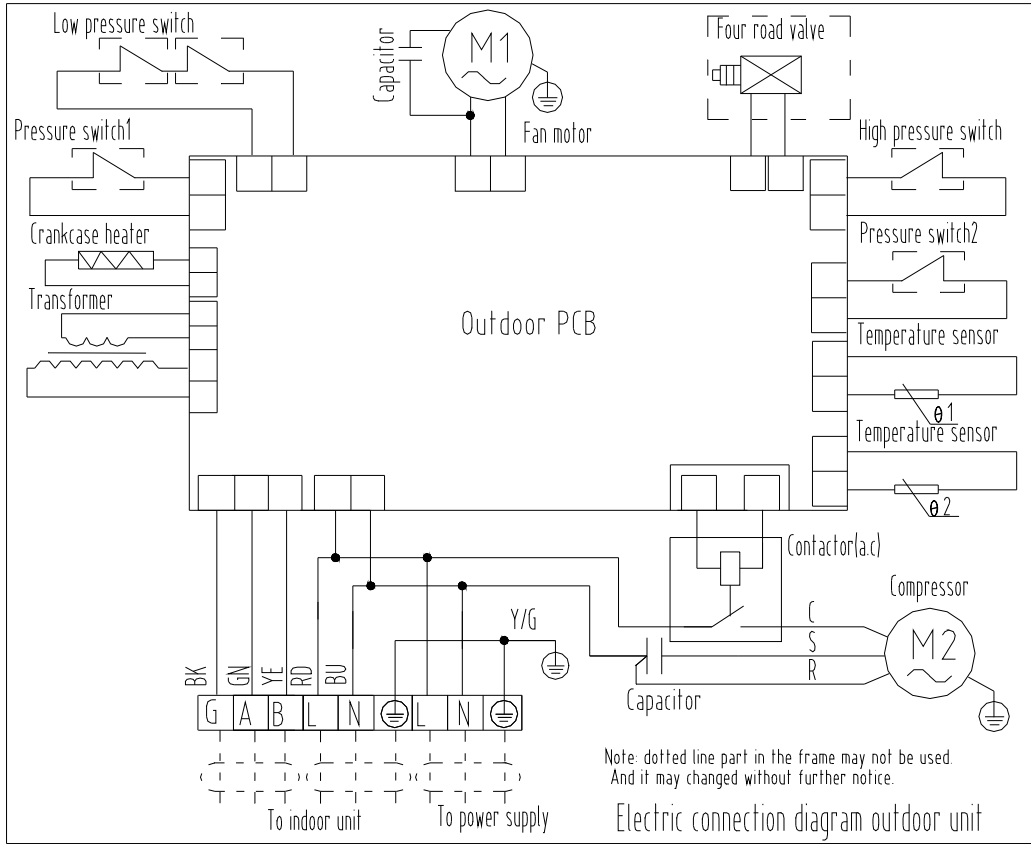

OC427

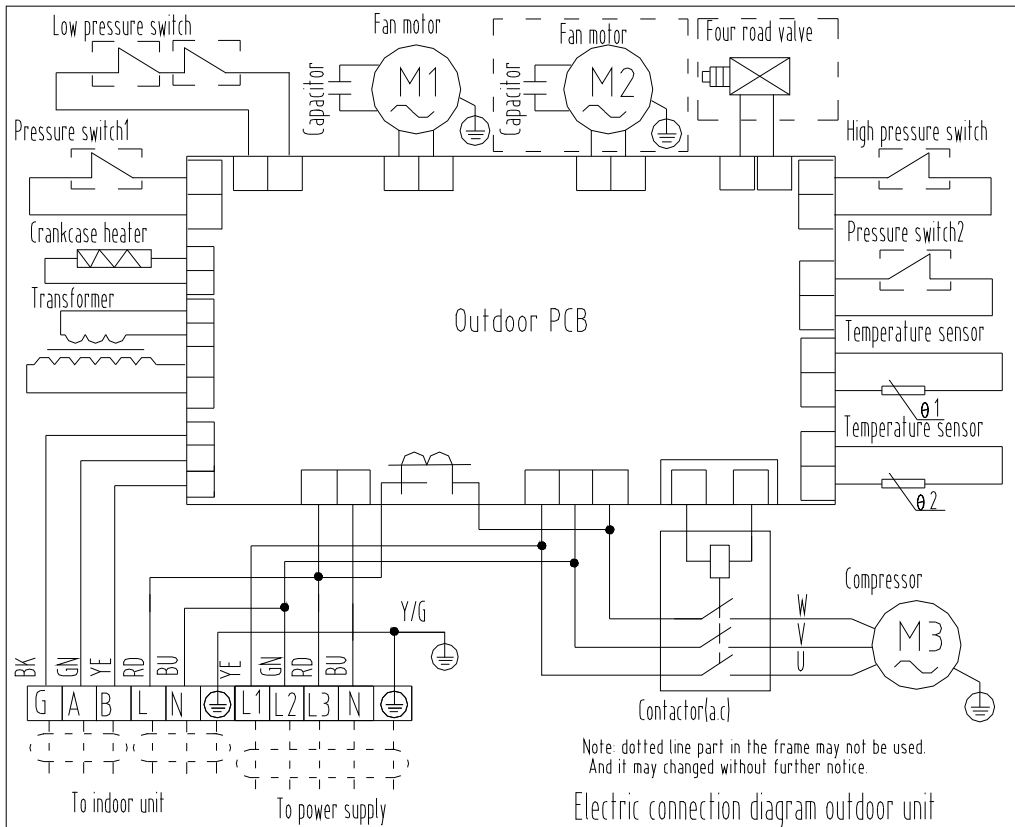

Appendix 5—System Settings



CAUTION

The system settings should only be modified by a trained and qualified professional as incorrect settings may cause malfunction or have unintended consequences. Do not modify these settings unless you are clear that you know what you are doing and are prepared to accept any consequences of doing so. Amending the system settings may invalidate the systems warranty.

Indoor & Outdoor Unit DIP Switches

These are factory set. Do not modify these or failure will result. When fitting a new PCB ensure that the settings on the new PCB are set the same as to the old PCB.

System Function Parameters in Software

These are set by entering System Function Select mode on the controller. This is entered by turning the system off and pressing and holding the OPTION button. Pressing the OPTION button will then scroll through the parameters and the TEMPERATURE UP / DOWN and TIME UP / DOWN buttons are used to change the settings of those parameters.

System Function Parameters are set by use of the time up and down buttons.

Function	Code	Factory	On
System Type	SA01	On	Electric Heat
System Type	SA02	On	Heat Pump
Fan Speeds	SA03	On	3 Fan Speeds
Defrost Type	SA04	On	Compressor On
Mode Change during Operation	SA07	On	Allowed
Auto Restart	SA08	On	Enabled
Repeat Timer	SA09	Off	Enabled
Remote Start Stop	SA10	Off	Enabled
Phase Protection	SA11	Off 187 & 247, On 427	Enabled
Swing Pattern	SA12	Off	Angle Pattern
Swing Direction	SA13	On	Clockwise
Standby	SA14		
Swing Area	SA15	On -187, Off - 247 & 427	Wide Angle

Temperature Set Back Parameters are set by use of the temperature up and down buttons.

Sensor	Code	Factory	Min	Max	Cancel
Indoor Air	PC01	0C	-9C	+9C	--
Indoor Pipe	PC02	0C	-9C	+9C	--
Outdoor Pipe	PC05	0C	-9C	+9C	--
Discharge Pipe	PC07	0C	-9C	+9C	--

Temperature Operation Parameters are set by use of the temperature up and down buttons. Please note electric heat is not available.

Setting	Code	Factory	Max	Min	Cancel
Deadband	SP01	1C	5C	1C	X
Deadband in Auto	SP02	5C	10C	3C	X
Elec Heat On	SP03	46C	60C	40C	--
Elec Heat Off	SP04	50C	60C	40C	--
Draft Prevention 1	SP05	25C	35C	20C	
Draft Prevention 2	SP06	35C	40C	30C	
Post Heat Fan 1	SP07	28C	35C	20C	
Post Heat Fan 2	SP08	35C	40C	30C	

Time Operation Parameters are set by use of the time up and down buttons.

Setting	Code	Factory	Max	Min	Cancel
Sample Temperature	SC01	3 secs	60 secs	0 secs	--
Max Swing Angle	SC02	46	100	10	--
Min Swing Angle	SC03	10	50	0	--
Comp Delay OD Fan	SC04	5 secs	60 secs	1 sec	
OD Fan Time Comp Delay	SC05	5 secs	60 secs	1sec	
Backlight On Time	SC06	10 secs	60 secs	3 secs	--
LCD Lit on Failure	SC07	10 secs	30 secs	3 secs	
Auto Mode Interval	SC08	10 mins	30 mins	0 mins	--

Temperature Protection Parameters are set by use of the temperature up and down buttons.

Setting	Code	Factory	Max	Min	Cancel
Cooling Mode De-Ice	EP01	-2C	10C	-5C	--
Cooling Mode Overload	EP02	60C	80C	51C	--
Heat Mode Hi Temp	EP04	66C	80C	45C	--
Overcurrent Protection	EP06	16C	50C	1C	
High Discharge Temp	EP08	120C	150C	50C	
Backlight On Time	SC06	10 secs	60 secs	3 secs	--
LCD Lit on Query	SC07	10 secs	30 secs	3 secs	
Auto Mode Interval	SC08	10 mins	30 mins	0 mins	--

Time Protection Parameters are set by use of the time up and down buttons.

Setting	Code	Factory	Max	Min	Cancel
Comp Start Protection	EC01	3 mins	10 mins	1 min	
Minimum Comp Run Time	EC02	3 mins	10 mins	1 min	
Max Anti Cold Air	EC03	15 secs	120 secs	0 secs	--
Max Fan Delay On Heat	EC04	15 secs	120 secs	0 secs	--
Outdoor Failure Delay	EC05	2 mins	5 mins	0 secs	
Duration of Protection	EC06	3 mins	10 secs	0 secs	
Water Pump Protection	EC07	30 secs	60 secs	1 sec	
Auto Mode Interval	SC08	10 mins	30 mins	0 mins	--

Defrost Operation Parameters are set by use of the temperature up and down buttons for temperature parameters and time up and down buttons for time pa-

Setting	Code	Factory	Max	Min	Cancel
OD Defrost Start Temp	HF01	3C	10C	-10C	--
OD Coil Defrost Start	HF03	-8C	0C	-10C	--
OD Coil Defrost Stop	HF04	16C	20C	5C	--
Comp Time Defrost Start	HF05	30 mins	90 mins	20 mins	
Max Defrost Time	HF06	8 mins	20 mins	3 mins	
Cycle Operation	HF08	20 secs	50 secs	10 secs	
Post Heat Fan 2		35C	40C	30C	

Appendix 6—Sensor Resistance Readings

Each system has four temperature sensors. These are -
 PC01—Indoor Air Sensor—Type A
 PC02—Indoor Pipe Sensor—Type A
 PC05—Outdoor Pipe Sensor—Type A
 PC07—Outdoor Discharge Sensor—Type B

Temp	PC01	PC02	PC05	PC07
-20C	37.0K	37.0K	37.0K	74.0K
-10C	22.6K	22.6K	22.6K	45.2K
0C	14.2K	14.2K	14.2K	28.5K
10C	9.2K	9.2K	9.2K	18.4K
20C	6.1K	6.1K	6.1K	12.2K
30C	4.1K	4.1K	4.1K	8.3K
50C	2.0K	2.0K	2.0K	4.1K
100C	0.5K	0.5K	0.5K	0.9K

The chart above shows the temperature / resistance values at different temperatures showing Resistance in KiloOhms.

Appendix 7—Trouble Shooting

SYMPTOM	CAUSE	REMEDY
No Cooling Or Heating		
No Display On Controller	Power Cut	Wait for Power restoration
	Power Off	Turn Power On
	Isolator Off	Turn On
	Indoor Unit Switch Off	Turn On
	Fuse Blown	Replace
	Faulty Connection	Repair
	Blown PCB	Replace
	Blown Transformer	Replace
	Blown Fuse on PCB	Replace
Controller operates but no compressor symbol displayed	Delay Timer Operating	Wait for 3 minutes
	Remote Stop Signal	Check Remote Switch
	Off on time clock	Advance Timer
	Incorrect Mode	Change Mode
	Incorrect Set Temperature	Set Correctly
Controller Operates & Compressor Symbol Displayed	Overheat Cutout	Let compressor cool
	Compressor Bypass	Let it reset (1 hour)
	Faulty Compressor	Test / Replace
Insufficient Cooling or Heating		
Temp Diff indoor Unit 10C or more	Doors / Windows Open	Close them
	Blinds Open	Shut them
	Too many people	Wait for some to leave
	Too much equipment	Remove some
	Set Temp too High/Low	Set Correctly
	Heating turned on	Turn Heating off
	Unit Undersized	More aircon needed
Temp Diff less than 10C	Low Gas Charge	Check & Recharge
	Outdoor air blocked	Clear Blockage
	System Blockage	Repair
	Too cold / hot outside	Ventilate Condensor
	Excess Gas Charge	Check & Recharge
	Lines Insulated together	Insulate Separately
Low Indoor Airflow	Dirty Filter	Clean
	Dirty Indoor Coil	Clean
	Fan Motor Faulty	Replace
	Capacitor Faulty	Replace
Compressor Runs Continuously		
Compressor Runs Continuously	Unit Undersized	More aircon needed
	Contaminated Gas	Replace
	Low Gas Charge	Check & Recharge
	Set Temp too High/Low	Set Correctly

SYMPTOM	CAUSE	REMEDY
Unit Short Cycles		
Compressor Starts & quickly shuts down	Air & Pipe sensor swapped	Check and swap
	System Blockage	Check / Repair
	System Contamination	Check / Repair
	Voltage too high / low	Check
	Gas charge incorrect	Check / Repair
Indoor Coil Freeze Up		
Ice Build Up on Indoor Coil	Low Gas Charge	Repair / Recharge
	Low Airflow	Dirty Filter / Coil
	Set Temp Too Low	Set Higher
	Unit Undersized	More Aircon Needed
Unit Noisy		
Faulty Installation	Vibration	Check Source
Compressor Noisy	Grinding Sound	Low Oil - Investigate
	Compressor Vibrating	Excess Gas Charge
Incorrect Discharge Pressure		
Discharge too high	High Gas Charge	Check / Repair
	Heat Exchangers Dirty	Clean
	Refrigerant Contamination	Check / Repair
	Dirty Filter (Heating)	Clean
Discharge too low	Low Gas Charge	Check / Repair
	Blockage	Check / Repair
Incorrect Suction Pressure		
Suction Too High	High Gas Charge	Check / Repair
	Unit Undersized	More Aircon Needed
	Faulty 4 way valve	Repair
Suction Too Low	Low Gas Charge	Check / Repair
	Blockage	Check / Repair
	Set Temp Too Low	Set Higher
	Dirty Filter or Coil	Clean

Appendix 8—Common Reasons for Fault Codes

These are common reasons for seeing the various fault codes and methods for resolving them.

Fault	Meaning	Suggestion
Eo00 or Er08	Comms Failure	Usually a broken cable or faulty connection Sometimes Interference—try screened cable?
Eo03	Phase Problem	Lost Phase—Check all 3 phases Swapped Phase—Try swapping 2 phases
Er04	High Pressure	Probably excess refrigerant or dirty filters / coils
Er05	Low Pressure	Usually low or no gas or a refrigerant circuit blockage
Er06	High Discharge	Usually low gas or a refrigerant circuit blockage
Er07	Overcurrent	Usually a blocked condenser coil or overloaded unit
Er11 or Pr11	Drain Problem	Usually blocked drains
Pr01,2,5 or 6	Pipe Sensor Problem	Clean the sensor connections
Pr03	De-Ice	Dirty filter or indoor coil—clean Set temperature too low—set higher Low Humidity—set temperature higher Low Gas Charge—Investigate
Pr04	Overload	Dirty Outdoor Coil—Clean Non Condensibles in Refrigerant—Recharge Excess Gas Charge—Recharge
Pr08	Heating High Temp	Dirty Filter or indoor coil—clean Set temperature too high—set lower Non Condensibles in Refrigerant—Recharge Excess Gas Charge—Recharge

Commissioning Sheet

Fill in during commissioning and retain a copy for your records. Leave this with the end user.

Name		Indoor Type		Indoor Ser No	
Company		Outdoor Type		Outdoor Ser No	
End User		Grille Type		Grille Ser No	
Date		Gas Type	R410a	Extra Gas (g)	
Voltage L1/L2		Voltage L1/N		Gas Pressures	
Voltage L2/L3		Run Amps Cool		Cooling	
Voltage L1/L3		Run Amps Heat		Heating	
Gas Line Dia		Gas Line Length		Vertical Lift	
Liquid Line Dia		Liq Line Length		Trap Qty	
Pump Used	Yes / No	Pump Type		Pump Lift	
Outdoor Unit	Wall / Floor	Outdoor Unit	Above / Below	Tower Req'd	Yes / No
Press Test psi		Test for (min)		Test Witness	
Vac Test micron		Test for (min)		Test Witness	

	Cooling	Heating
Indoor Inlet Air Temp		
Indoor Outlet Air Temp		
Indoor Coil Temp		
Outdoor Inlet Air Temp		
Outdoor Outlet Air Temp		
Outdoor Disch Pipe Temp		
Outdoor Coil Temp		
Outdoor Gas Pipe Temp		
Outdoor Liq Pipe Temp		

Sketch Pipe Layout Below

Comments

I confirm I have explained the workings of the machine to the user and carried out the commissioning tests required in this manual

Signed
Date

For further information telephone 01743 466333
Or visit our website at www.medalaircon.co.uk



Whilst every care has been taken to ensure that the information included in this document was accurate at the time of printing, we reserve the right to change specifications at any time. The photographs reproduced in this publication are within the constraints of the printing process and are NOT to be used for matching purposes. E&OE.

AUX

DE-COMMISSIONING, DISMANTLING & DISPOSAL

This product contains refrigerant under pressure, rotating parts, and electrical connections which may be a danger & cause injury!
All work must only be carried out by competent persons using suitable protective clothing and safety precautions.



Read the Manual



Risk of Electric Shock

RoHS



Unit is Remotely controlled
& may start without warning



1. Isolate all sources of electrical supply to the unit including any control system supplies switched by the unit. Ensure that all points of electrical and gas isolation are secured in the OFF position. The supply cables and gas pipe work may then be disconnected and removed. For points of connection refer to unit installation instructions.
2. Remove all refrigerant from each system of the unit into a suitable container using a refrigerant reclaim or recovery unit. This refrigerant may then be reused, if appropriate, or returned to the manufacturer for disposal. **Under No circumstances should refrigerant be vented to atmosphere.** Where appropriate, drain the refrigerant oil from each system into a suitable container and dispose of according to local laws and regulations governing disposal of oily wastes.
3. Packaged units can generally be removed in one piece after disconnection as above. Any fixing down bolts should be removed and then unit lifted from position using the points provided and equipment of adequate lifting capacity. Reference MUST be made to the unit installation instructions for unit weight and correct methods of lifting. Note that any residual or spilt refrigerant oil should be mopped up and disposed of as described above.
4. After removal from position the unit parts may be disposed of according to local laws and regulations.
5. Meaning of crossed-out wheeled dustbin: Do not dispose of electrical appliances as unsorted municipal waste, use separate collection facilities. Contact your local government for information regarding the collection systems available. If electrical appliances are disposed of in landfills or dumps, hazardous substances can leak into the groundwater and get into the food chain, damaging your health and well-being. When replacing old appliances with new ones, the retailer is legally obligated to take back your old appliance for disposals at least free of charge.